

JVC

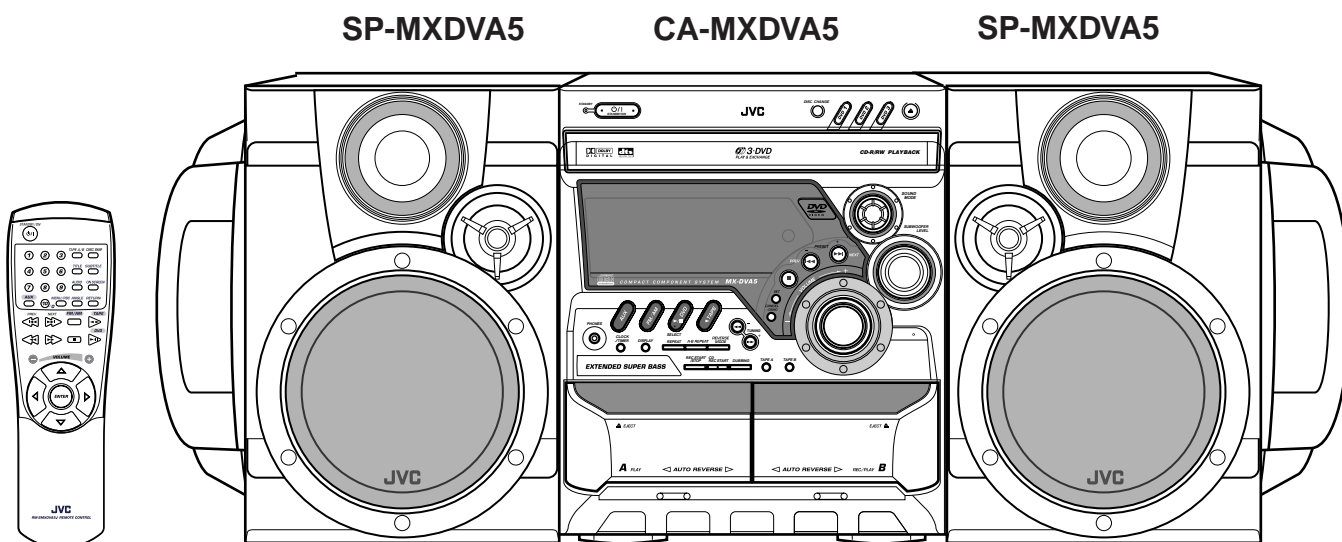

COMPACT COMPONENT SYSTEM

MX-DVA5 — Consists of CA-MXDVA5 and SP-MXDVA5



INSTRUCTIONS

For Customer Use:

Enter below the Model No. and Serial No. which are located either on the rear, bottom or side of the cabinet. Retain this information for future reference.

Model No. _____

Serial No. _____

LVT0701-001A

[J]

Warnings, Cautions and Others

Mises en garde, précautions et indications diverses

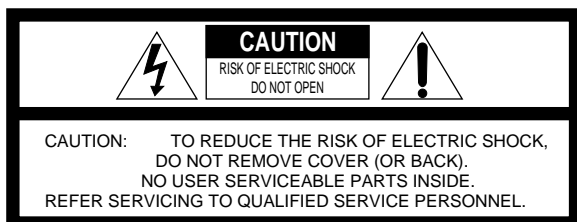

The lightning flash with arrowhead symbol, within an equilateral triangle is intended to alert the user to the presence of uninsulated "dangerous voltage" within the product's enclosure that may be of sufficient magnitude to constitute a risk of electric shock to persons.



The exclamation point within an equilateral triangle is intended to alert the user to the presence of important operating and maintenance (servicing) instructions in the literature accompanying the appliance.

For U.S.A.

This equipment has been tested and found to comply with the limits for a Class B digital device, pursuant to part 15 of the FCC Rules. These limits are designed to provide reasonable protection against harmful interference in a residential installation.

This equipment generates, uses and can radiate radio frequency energy and, if not installed and used in accordance with the instructions, may cause harmful interference to radio communications. However, there is no guarantee that interference will not occur in a particular installation. If this equipment does cause harmful interference to radio or television reception, which can be determined by turning the equipment off and on, the user is encouraged to try to correct the interference by one or more of the following measures:

Reorient or relocate the receiving antenna.
Increase the separation between the equipment and receiver.
Connect the equipment into an outlet on a circuit different from that to which the receiver is connected.
Consult the dealer or an experienced radio/TV technician for help.

WARNING: TO REDUCE THE RISK OF FIRE OR ELECTRIC SHOCK, DO NOT EXPOSE THIS APPLIANCE TO RAIN OR MOISTURE.

Caution — STANDBY/ON switch!

Disconnect the mains plug to shut the power off completely. The  STANDBY/ON switch in any position does not disconnect the mains line. The power can be remote controlled.

Attention — Commutateur STANDBY/ON!

Déconnecter la fiche de secteur pour couper complètement le courant. Le commutateur  STANDBY/ON ne coupe jamais complètement la ligne de secteur, quelle que soit sa position. Le courant peut être télécommandé.

CAUTION

To reduce the risk of electrical shocks, fire, etc.:

1. Do not remove screws, covers or cabinet.
2. Do not expose this appliance to rain or moisture.

CAUTION

- Do not block the ventilation openings or holes. (If the ventilation openings or holes are blocked by a newspaper or cloth, etc., the heat may not be able to get out.)
- Do not place any naked flame sources, such as lighted candles, on the apparatus.
- When discarding batteries, environmental problems must be considered and local rules or laws governing the disposal of these batteries must be followed strictly.
- Do not use this apparatus in a bathroom or places with water. Also do not place any containers filled with water or liquids (such as cosmetics or medicines, flower vases, potted plants, cups, etc.) on top of this apparatus.

ATTENTION

Afin d'éviter tout risque d'électrocution, d'incendie, etc.:

1. Ne pas enlever les vis ni les panneaux et ne pas ouvrir le coffret de l'appareil.
2. Ne pas exposer l'appareil à la pluie ni à l'humidité.

ATTENTION

- Ne bloquez pas les orifices ou les trous de ventilation. (Si les orifices ou les trous de ventilation sont bloqués par un journal un tissu, etc., la chaleur peut ne pas être évacuée correctement de l'appareil.)
- Ne placez aucune source de flamme nue, telle qu'une bougie, sur l'appareil.
- Lors de la mise au rebut des piles, veuillez prendre en considération les problèmes de l'environnement et suivre strictement les règles et les lois locales sur la mise au rebut des piles.
- N'utilisez pas cet appareil dans une salle de bain ou un autre endroit avec de l'eau. Ne placez aucun récipient contenant de l'eau (tel que des cosmétiques ou des médicaments, un vase de fleurs, un pot de fleurs, une tasse, etc.) sur cet appareil.

1. CLASS 1 LASER PRODUCT

2. **DANGER:** Invisible laser radiation when open and interlock failed or defeated. Avoid direct exposure to beam.
3. **CAUTION:** Do not open the top cover. There are no user serviceable parts inside the Unit; leave all servicing to qualified service personnel.

1. PRODUIT LASER CLASSE 1

2. **ATTENTION:** Radiation laser invisible quand l'appareil est ouvert ou que le verrouillage est en panne ou désactivé. Éviter une exposition directe au rayon.
3. **ATTENTION:** Ne pas ouvrir le couvercle du dessus. Il n'y a aucune pièce utilisable à l'intérieur. Laisser à un personnel qualifié le soin de réparer votre appareil.

For Canada/pour le Canada

CAUTION: TO PREVENT ELECTRIC SHOCK, MATCH WIDE BLADE OF PLUG TO WIDE SLOT, FULLY INSERT.

ATTENTION: POUR EVITER LES CHOCS ELECTRIQUES, INTRODUIRE LA LAME LA PLUS LARGE DE LA FICHE DANS LA BORNE CORRESPONDANTE DE LA PRISE ET POUSSER JUSQU'AU FOND.

For Canada/pour le Canada

THIS DIGITAL APPARATUS DOES NOT EXCEED THE CLASS B LIMITS FOR RADIO NOISE EMISSIONS FROM DIGITAL APPARATUS AS SET OUT IN THE INTERFERENCE-CAUSING EQUIPMENT STANDARD ENTITLED "DIGITAL APPARATUS," ICES-003 OF THE DEPARTMENT OF COMMUNICATIONS.

CET APPAREIL NUMERIQUE RESPECTE LES LIMITES DE BRUITS RADIOELECTRIQUES APPLICABLES AUX APPAREILS NUMIRIQUES DE CLASSE B PRESCRITES DANS LA NORME SUR LE MATERIEL BROUILLEUR: "APPAREILS NUMERIQUES", NMB-003 EDICTEE PAR LE MINISTRE DES COMMUNICATIONS.

Introduction

We would like to thank you for purchasing one of our JVC products. Before operating this unit, read this manual carefully and thoroughly to obtain the best possible performance from your unit, and retain this manual for future reference.

About This Manual

This manual is organized as follows:

- The manual mainly explains operations using the buttons and controls on the unit. You can also use the buttons on the remote control if they have the same or similar names (or marks) as those on the unit. If operation using the remote control is different from that using the unit, it is then explained.
- Basic and common information that is the same for many functions is grouped in one place, and is not repeated in each procedure. For instance, we do not repeat the information about turning on/off the unit, setting the volume, changing the sound effects, and others, which are explained in the section “Common Operations” on pages 10 to 12.
- The following marks are used in this manual:



Gives you warnings and cautions to prevent damage or risk of fire/electric shock. Also gives you information which is not good for obtaining the best possible performance from the unit.



Gives you information and hints you had better know.

Precautions

Installation

- Install in a place which is level, dry and neither too hot nor too cold — between 5°C (41°F) and 35°C (95°F).
- Install the unit in a location with adequate ventilation to prevent internal heat built-up in the unit.
- Leave sufficient distance between the unit and the TV.
- Keep the speakers away from the TV to avoid interference with TV.



DO NOT install the unit in a location near heat sources, or in a place subject to direct sunlight, excessive dust or vibration.

Power sources

- When unplugging from the wall outlet, always pull the plug, not the AC power cord.



DO NOT handle the AC power cord with wet hands.

Moisture condensation

Moisture may condense on the lens inside the unit in the following cases:

- After starting heating in the room
 - In a damp room
 - If the unit is brought directly from a cold to a warm place
- Should this occur, the unit may malfunction. In this case, leave the unit turned on for a few hours until the moisture evaporates, unplug the AC power cord, and then plug it in again.

Others

- Should any metallic object or liquid fall into the unit, unplug the unit and consult your dealer before operating any further.
- If you are not going to operate the unit for an extended period of time, unplug the AC power cord from the wall outlet.



DO NOT disassemble the unit since there are no user serviceable parts inside.

If anything goes wrong, unplug the AC power cord and consult your dealer.

Contents

Location of the Buttons and Controls	3	VCD/CD Playback	23
Front Panel	3	Showing the On-Screen Bar	23
Remote Control	5	Disc Menu-Driven Playback (Only for VCD)	23
Getting Started	6	Moving to a Particular Portion Directly	24
Unpacking	6	Searching for a Particular Point	24
Putting the Batteries into the Remote Control	6	• Various Speed Forward Search	24
Connecting Antennas	6	• Various Speed Reverse Search	24
Connecting Speakers	7	Repeating Playback	25
Connecting Other Equipment	8	• Repeat Play	25
Cancelling the Display Demonstration	9	• A-B Repeat	25
Common Operations	10	Programming the Playing Order of the Tracks	
Turning On and Off the Power	10	—Program Play	26
Setting the Clock	10	VCD Special Effect Playback	27
Selecting the Sources	10	• Still Picture/Frame-by-Frame Playback	27
Adjusting the Volume	11	• Slow Motion Playback	27
Reinforcing the Bass Sound	11	• Zoom	27
Selecting the Sound Modes	12	Setting up the DVD Operations	28
Creating a Being-There Feeling	12	Setting the Initial Languages	28
Listening to FM and AM Broadcasts	13	Setting the DVD Preference (System)	29
Tuning in a Station	13	Setting the Parental Lock	30
Presetting Stations	13	Playing Back Tapes	31
Tuning in a Preset Station	13	Playing Back a Tape	31
Disc Introduction—DVD/VCD/CD	14	Recording	32
Basic Disc Operations	15	Recording a Tape on Deck B	32
Loading Discs	15	Dubbing Tapes	33
Playing Back Discs	15	CD Synchronized Recording	33
Prohibiting Disc Ejection—Tray Lock	16	Using the Timers	34
DVD Playback	17	Using Daily Timer	34
Showing the On-Screen Bar	17	Using Recording Timer	35
Selecting the Subtitles	18	Using Sleep Timer	36
Selecting the Audio Languages	18	Timer Priority	36
Selecting the Multi-Angle Views	18	Maintenance	37
Disc Menu-Driven Playback	19	Troubleshooting	38
Moving to a Particular Portion Directly	19	Glossary	39
Searching for a Particular Point	20	Specifications	40
• Various Speed Forward Search	20		
• Various Speed Reverse Search	20		
Repeating Playback	20		
• Repeat Play	20		
• A-B Repeat	20		
Programming the Playing Order of the Chapters			
—Program Play	21		
DVD Special Effect Playback	22		
• Still Picture/Frame-by-Frame Playback	22		
• Slow Motion Playback	22		
• Zoom	22		

Location of the Buttons and Controls

Become familiar with the buttons and controls on your unit.

Front Panel

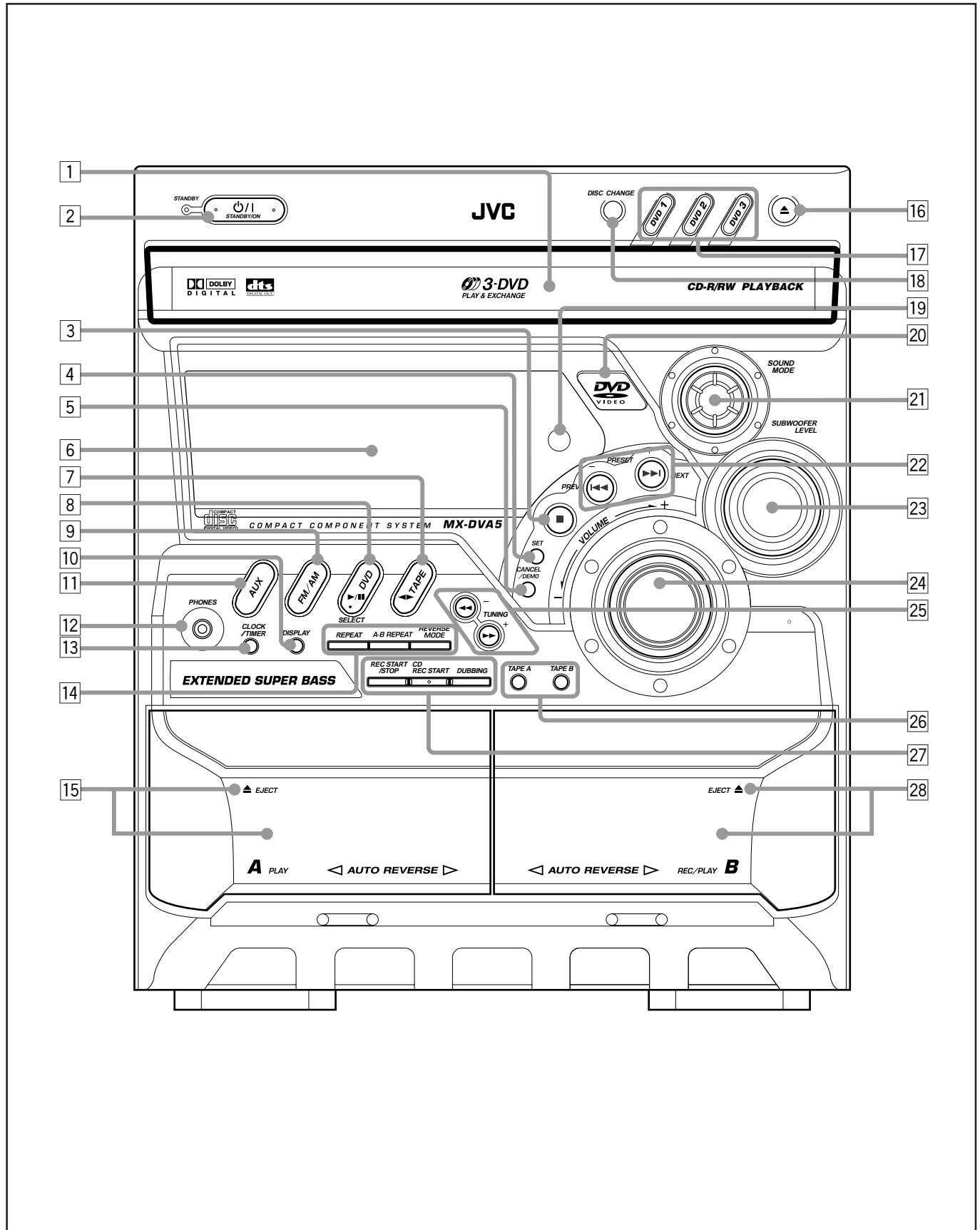

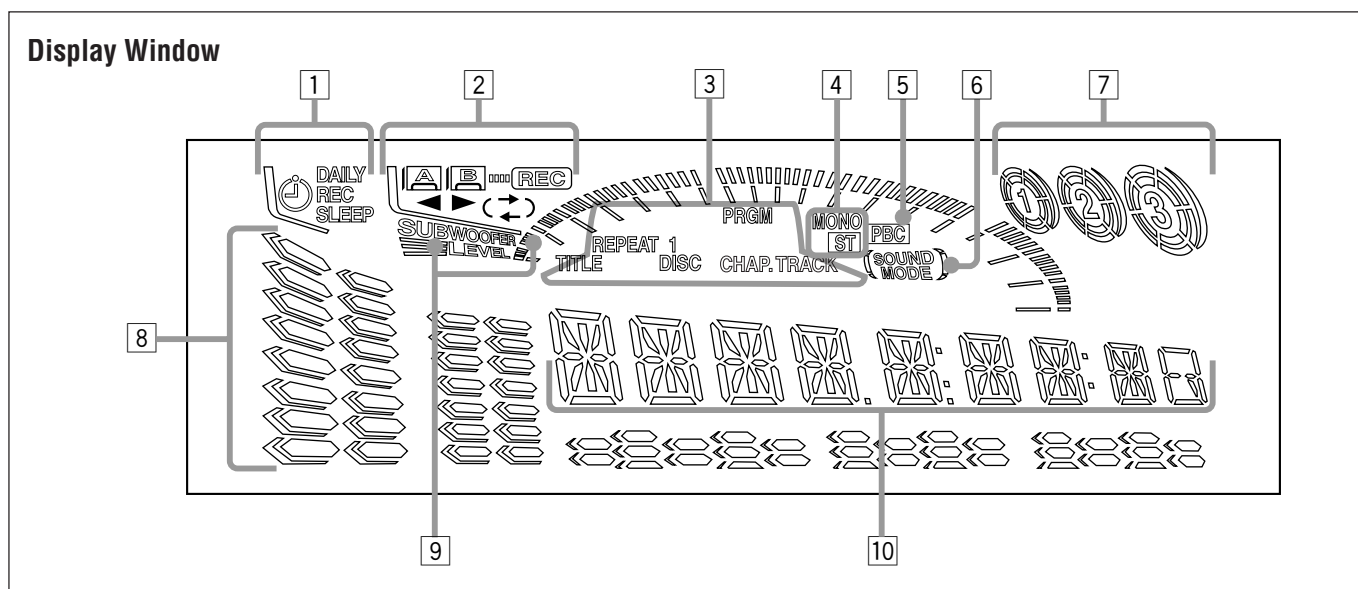

See pages in the parentheses for details.

Front Panel

- 1 Carrousel
- 2 / I STANDBY/ON button and STANDBY lamp (10, 35, 36)
- 3 (stop) button (15, 21, 23, 26, 32, 33)
- 4 SET button (10, 13, 34 – 36)
- 5 CANCEL/DEMO button (9, 10, 34 – 36)
- 6 Display window
- 7 TAPE button and lamp (10, 31 – 33)
 - Pressing this button also turns on the unit.
- 8 DVD / (play/pause) (SELECT) button and lamp (10, 15, 16, 21, 23, 26)
 - Pressing this button also turns on the unit.
- 9 FM/AM button and lamp (10, 13)
 - Pressing this button also turns on the unit.
- 10 DISPLAY button (10)
- 11 AUX button and lamp (10)
 - Pressing this button also turns on the unit.
- 12 PHONES jack (11)
- 13 CLOCK/TIMER button (10, 34 – 36)
- 14 Repeat/reverse mode buttons
 - REPEAT button (20, 25)
 - A-B REPEAT button (20, 25)
 - REVERSE MODE button (31 – 33)
- 15 Deck A cassette holder
 - Pressing the EJECT portion opens the holder.
- 16 (Carrousel open/close) button (15, 16, 21, 26)
 - Pressing this button also turns on the unit.
- 17 Disc number buttons and lamps (DVD1, DVD2, and DVD3) (15, 16, 21, 26, 33)
 - Pressing one of these buttons also turns on the unit.
- 18 DISC CHANGE button (15, 16)
- 19 Remote sensor
- 20 DVD VIDEO lamp (10, 30)
- 21 SOUND MODE control (12)

- 22 PRESET + / – buttons (13)
 - ◀◀ / ▶▶ (reverse skip/forward skip) buttons (10, 16, 34 – 36)
 - PREV. (previous) / NEXT buttons (23)
- 23 SUBWOOFER LEVEL control (11)
- 24 VOLUME control (11)
- 25 TUNING + / – buttons (13)
 - ◀◀ / ▶▶ (fast left/fast right) buttons (31)
- 26 TAPE A button (31)
 - TAPE B button (30, 31)
- 27 Recording buttons
 - REC START/STOP button (32)
 - CD REC START button (33)
 - DUBBING button (33)
- 28 Deck B cassette holder
 - Pressing the EJECT portion opens the holder.

Display window

- 1 Timer indicators
 - DAILY (daily timer), REC (recording timer), SLEEP (sleep timer), and (timer) indicators
- 2 Tape operation indicators
 - A/B (operating deck), REC (recording), (tape direction) and (reverse mode) indicators
- 3 Disc play mode indicators
 - REPEAT (1, 1 DISC), TITLE, PRGM (program), and CHAP.TRACK indicators
- 4 Tuner operation indicators
 - MONO and ST (stereo) indicators
- 5 PBC indicator
- 6 SOUND MODE indicator
- 7 Disc indicators
- 8 Volume level, Subwoofer level, and Sound Mode pattern indicators
- 9 SUBWOOFER LEVEL indicator
- 10 Main display
 - Shows the source name, frequency, etc.

Remote Control

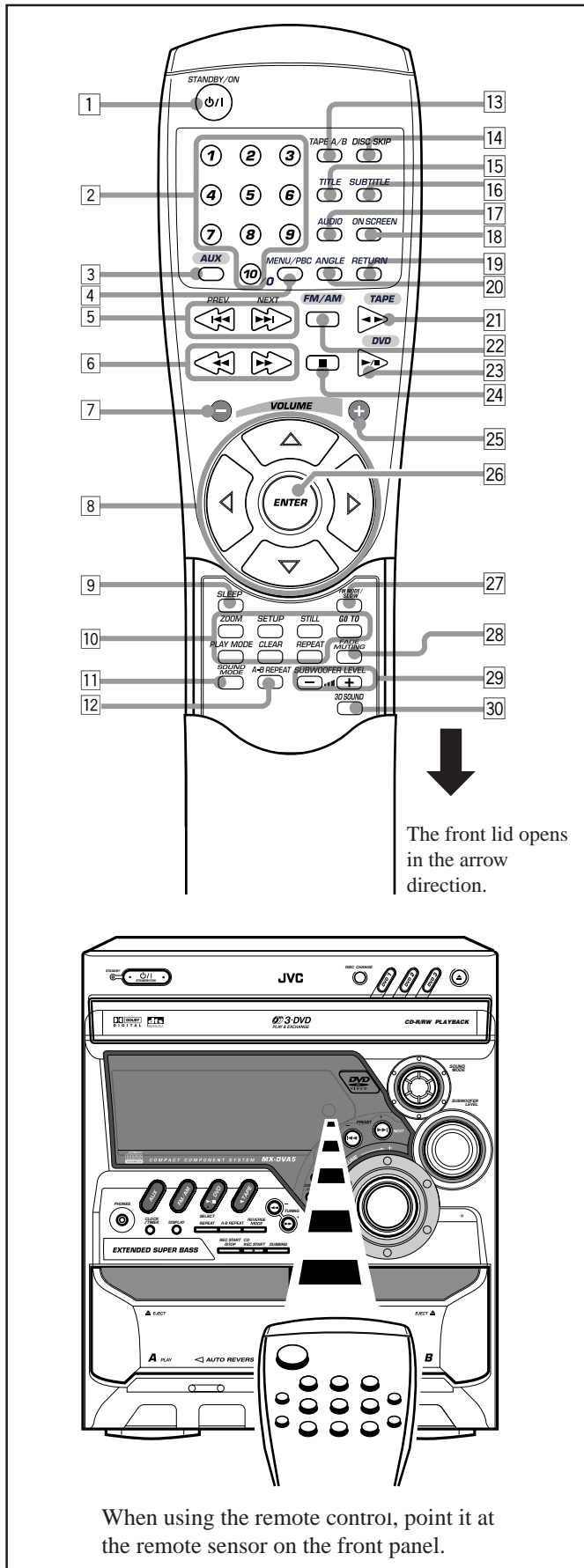

Remote Control

- 1 $\text{\textcircled{P}}/\text{I}$ STANDBY/ON button (10)
- 2 Number buttons (13, 16, 19)
- 3 AUX button (10)
 - Pressing this button also turns on the unit.
- 4 MENU/PBC button (19, 23)
- 5 $\text{◀◀} / \text{▶▶}$ buttons (16)
 - PREV.(previous) / NEXT buttons (23)
- 6 $\text{◀◀} / \text{▶▶}$ buttons (13, 20, 24, 31)
- 7 VOLUME – button (11)
- 8 Cursor (\blacktriangle \blacktriangledown \blacktriangleleft \blacktriangleright) buttons
- 9 SLEEP button (36)
- 10 Disc operation buttons
 - ZOOM button (22)
 - SETUP button (28 – 30)
 - STILL button (16, 22, 27)
 - GO TO button (19, 24)
 - PLAY MODE button (21, 26)
 - CLEAR button (19, 22, 24, 27)
 - REPEAT button (20, 25)
- 11 SOUND MODE button (12)
- 12 A-B REPEAT button (20, 25)
- 13 TAPE A/B button (31)
- 14 DISC SKIP button (15, 16)
- 15 TITLE button (19)
- 16 SUBTITLE button (18)
- 17 AUDIO button (18)
- 18 ON SCREEN button (17, 23)
- 19 RETURN button (23)
- 20 ANGLE button (18)
- 21 TAPE ◀▶ button (10, 31)
 - Pressing this button also turns on the unit.
- 22 FM/AM button (10, 13)
 - Pressing this button also turns on the unit.
- 23 DVD $\text{▶} / \text{||}$ button (10, 15, 16, 21, 23, 26, 27)
 - Pressing this button also turns on the unit.
- 24 \blacksquare (stop) button (15, 21, 23, 32)
- 25 VOLUME + button (11)
- 26 ENTER button (19, 21, 22, 24, 26 – 30)
- 27 FM MODE/SLOW button (13, 22, 27)
- 28 FADE MUTING button (11)
- 29 SUBWOOFER LEVEL + / – buttons (11)
- 30 3D SOUND button (12)

How to open the front lid

Press center part of the lid and pull down.

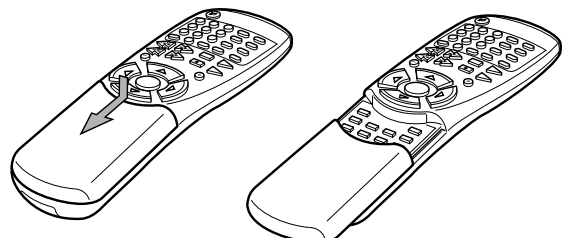

Unpacking

After unpacking, check to be sure that you have all the following items.
The number in the parentheses indicates the quantity of the pieces supplied.

- AM loop antenna (1)
- FM antenna (1)
- Remote control (1)
- Batteries (2)
- Composite video cord (1)

If any is missing, consult your dealer immediately.

Putting the Batteries into the Remote Control

Insert the batteries — UM-4/AAA/IEC R03 — into the remote control, by matching the polarity (+ and -) on the batteries with the + and - markings on the battery compartment.

When the remote control can no longer operate the unit, replace both batteries at the same time.

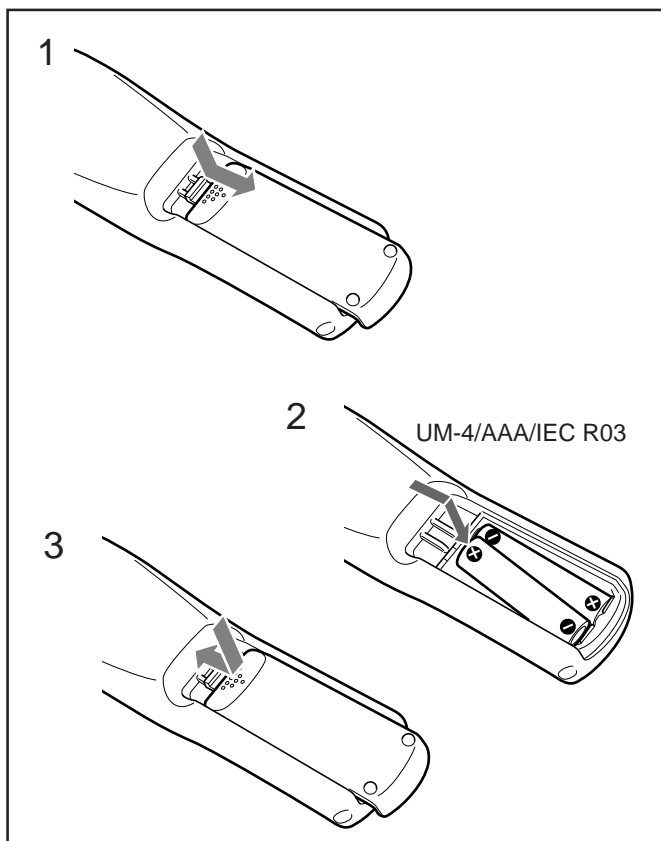

- DO NOT use an old battery together with a new one.
- DO NOT use different types of batteries together.
- DO NOT expose batteries to heat or flame.
- DO NOT leave the batteries in the battery compartment when you are not going to use the remote control for an extended period of time. Otherwise, it will be damaged from battery leakage.

Connecting Antennas

FM antenna

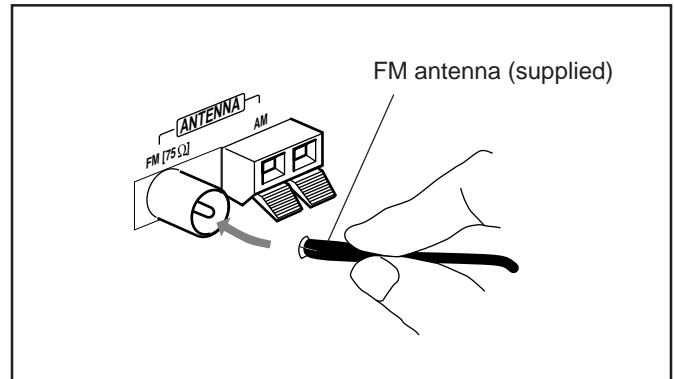

- 1 Attach the FM antenna to the FM [75 Ω] coaxial terminal.
- 2 Extend the FM antenna.
- 3 Fasten it up in the position which gives you the best reception, then fix it on the wall, etc.



About the supplied FM antenna

The FM antenna supplied with this unit can be used as temporary measure. If reception is poor, you can connect an outdoor FM antenna.

To connect an outdoor FM antenna

Before connecting it, disconnect the supplied FM antenna.

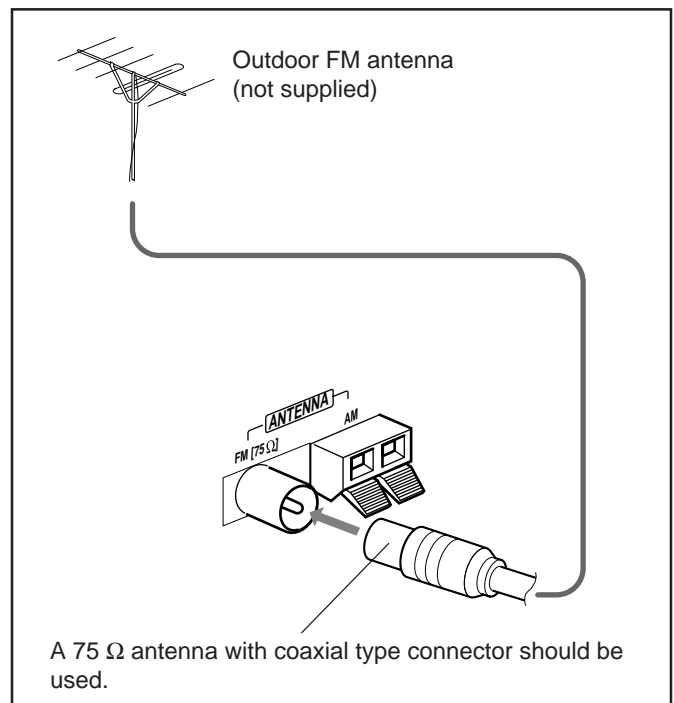

AM antenna

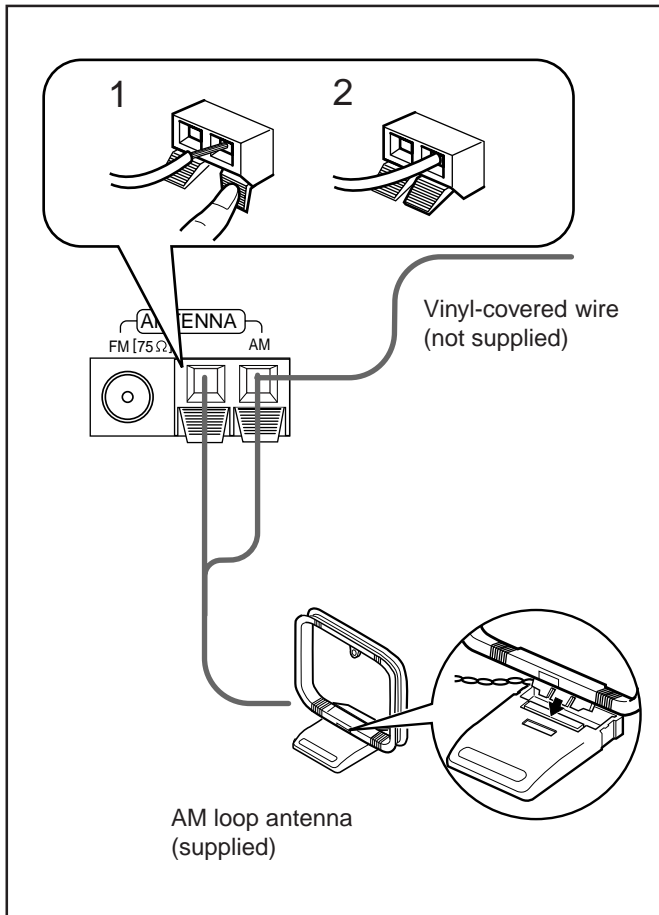

- 1 Press and hold the clamp of the AM terminals on the rear of the unit.
- 2 Insert the end of the AM loop antenna cord into the terminal.
- 3 Release the finger from the clamp.
- 4 Turn the AM loop antenna until you have the best reception.

To connect an outdoor AM antenna

When reception is poor, connect a single vinyl-covered wire to the AM terminal and extend it horizontally. (The AM loop antenna must remain connected.)



For better reception of both FM and AM

- Make sure the antenna conductors do not touch any other terminals and connecting cords.
- Keep the antennas away from metallic parts of the unit, connecting cords, and the AC power cord.

Connecting Speakers

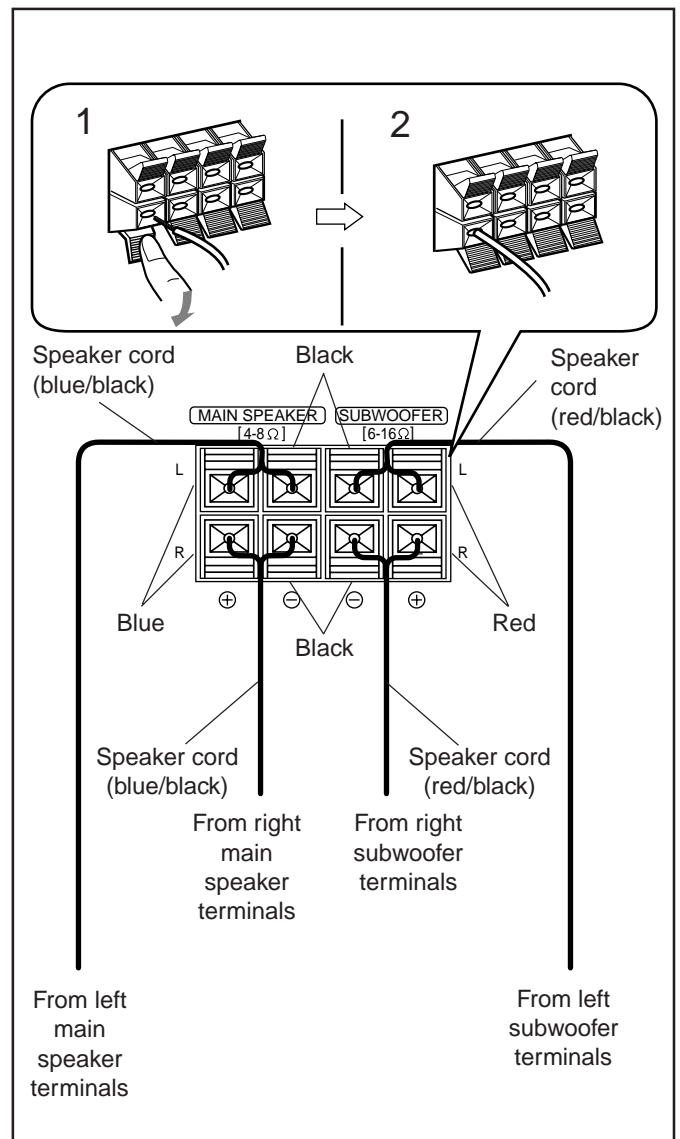

- 1 Press and hold the clamp of the speaker terminal on the rear of the unit.
- 2 Insert the end of the speaker cord into the terminal.
Match the polarity (colors): Blue (+) to blue (+) and black (-) to black (-); Red (+) to red (+) and black (-) to black (-).
- 3 Release the finger from the clamp.

IMPORTANT: Use only speakers with the same speaker impedance as indicated by the speaker terminals on the rear of the unit.

Connecting Other Equipment



- DO NOT connect any equipment while the power is on.
- DO NOT plug in any equipment until all connections are complete.

To connect the TV

Connect your TV and this unit using the composite video cord (supplied) or an S-video cord (not supplied).

- After connection is correctly done, set “VIDEO OUTPUT” setting correctly (see page 29); otherwise, no picture will be shown on the TV screen.

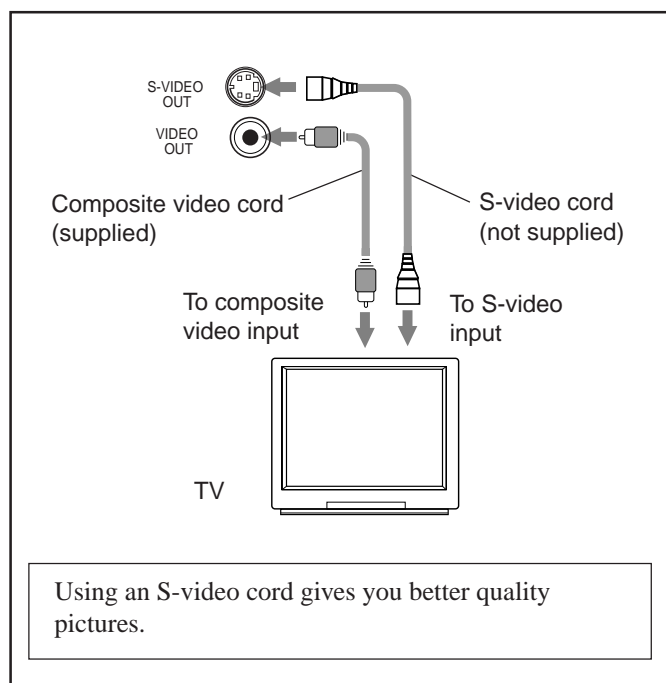

To connect other audio components

■ Analog components

Be sure that the plugs of the audio cords are color coded: White plugs and jacks are for left audio signals, and red ones for right audio signals.

For playing the other equipment through this unit, connect between the audio output jacks on the other equipment and the AUX IN jacks by using an audio cord (not supplied).

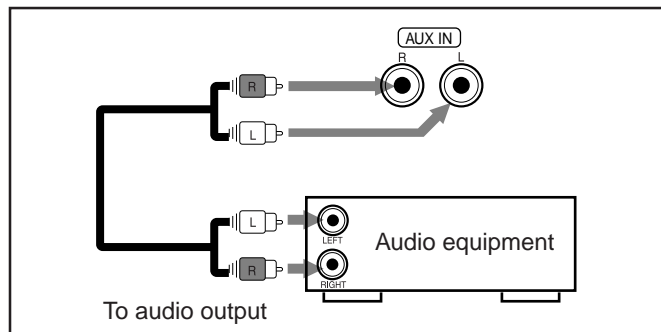

For recording sounds through this unit on the other equipment, connect between the audio input jacks on the other equipment and the LINE OUT jacks by using an audio cord (not supplied).

- See “About sounds reproduced through the rear terminals” on page 9.

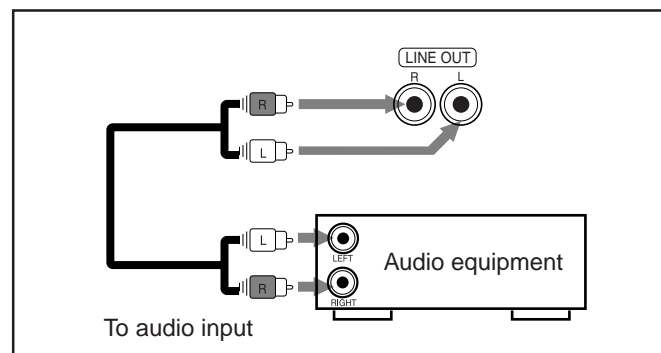

To connect audio equipment with an optical digital input terminal — such as digital decoder

You can connect a digital decoder or MD recorder by using an optical digital cord (not supplied).

- See “About sounds reproduced through the rear terminals” on the right column.

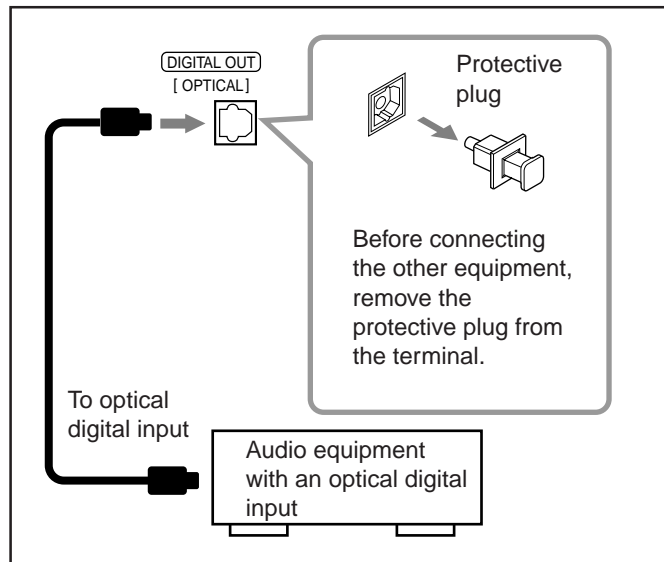

NOW, you can plug in the unit and other connected equipment FINALLY!

When connecting the AC power cord into a wall outlet, the unit automatically starts display demonstration.

Canceling the Display Demonstration

On the unit ONLY:

To cancel the display demonstration, press CANCEL/DEMO.



When you press other buttons

The display demonstration stops temporarily. It will start automatically again (if no operation is done for 2 minutes) until you cancel it by pressing CANCEL/DEMO.

To start the display demonstration manually

Press and hold CANCEL/DEMO again for more than 2 seconds.



About sounds reproduced through the rear terminals

• Through the LINE OUT (L/R) jacks and MAIN SPEAKERS/SUBWOOFER terminals:

Analog stereo signals are output.

When playing a source encoded with Dolby Digital* (DOLBY DIGITAL), multichannel signals are mixed to the left and right front channel signals, then output.

– You cannot reproduce the sound encoded DTS Digital Surround** (DTS).

• Through the DIGITAL OUT (OPTICAL) terminal:

Digital signals (Linear PCM, Dolby Digital, DTS Digital Surround) are output through this terminal. To reproduce the multichannel sounds such as Dolby Digital and DTS Digital Surround, connect an amplifier or a decoder compatible with these multichannel sources to this terminal, and set “DIGITAL OUTPUT” settings correctly. (See page 29.)

* Manufactured under license from Dolby Laboratories.

“Dolby” and the double-D symbol are trademarks of Dolby Laboratories. Confidential Unpublished Works. ©1992–1997 Dolby Laboratories. All rights reserved.

** Manufactured under license from Digital Theater Systems, Inc. US Pat. No. 5,451,942 and other world-wide patents issued and pending. “DTS” is a registered trademark of Digital Theater Systems, Inc. Copyright 1996, 2000 Digital Theater Systems, Inc. All Rights Reserved.

Turning On and Off the Power

To turn on the unit, press  STANDBY/ON so that the STANDBY lamp goes off.

- When the unit is turned on, the DVD VIDEO lamp on the unit lights up.

WELCOME

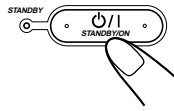

To turn off the unit (on standby), press  STANDBY/ON again so that the STANDBY lamp lights up.

- When the unit is turned on, the DVD VIDEO lamp on the unit goes off.

GOOD BYE

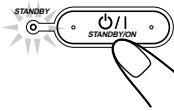

A little power is always consumed even while the unit is on standby.

To switch off the power supply completely, unplug the AC power cord from the AC outlet.

notes When you unplug the AC power cord or if a power failure occurs

The clock is reset to “-- : --,” while the tuner preset stations (see page 13) will be erased in a few days.

Setting the Clock

Before operating the unit any further, first set the clock built in this unit. You can set the clock whether the unit is on or off.

On the unit ONLY:

1 Press CLOCK/TIMER.

FM 12:00



The hour digits start flashing on the display.

2 Press or to adjust the hour, then press SET.

FM 5:00

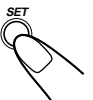

- If you want to correct the hour after pressing SET, press CANCEL/DEMO. The hour digits start flashing again.

3 Press or to adjust the minute, then press SET.

CLOCK OK

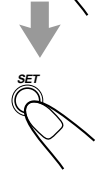
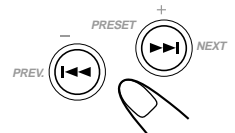

To check the clock time

Press DISPLAY while playing a source.

- Each time you press the button, the source indication and the clock time alternate on the display.

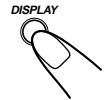

To adjust the clock again

If you have adjusted the clock before, you need to press CLOCK/TIMER repeatedly until “CLOCK” is selected.

- Each time you press the button, the clock/timer setting modes change as follows:

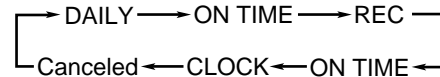

notes If there is a power failure

The clock loses the setting and is reset to “-- : --.” You need to set the clock again.

Selecting the Sources



To listen to the FM/AM broadcasts, press FM/AM. (See page 13.)

To play back discs, press DVD . (See pages 14 – 27.)

To play back tapes, press TAPE . (See page 31.)

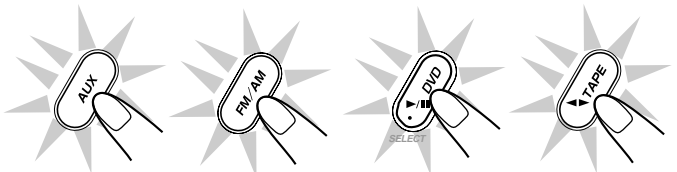
To select the external equipment as the source, press AUX.



When you press the play button for a particular source (AUX, FM/AM, DVD , and TAPE ), the unit turns on and the unit starts playing the source if it is ready.

Adjusting the Volume

You can adjust the volume level only while the unit is turned on.

Turn the VOLUME control clockwise to increase the volume or counterclockwise to decrease it.

- The volume level can be adjusted in 32 steps (VOL MIN, VOL 1 — VOL 30, and VOL MAX).

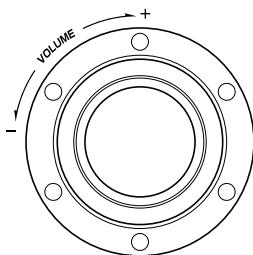

VOL 15

When using the remote control, press VOLUME + to increase the volume or press VOLUME - to decrease it.



For private listening

Connect a pair of headphones to the PHONES jack. No sound comes out of the speakers. Be sure to turn down the volume before connecting or putting on headphones.



DO NOT turn off (on standby) the unit with the volume set to an extremely high level; otherwise, a sudden blast of sound can damage your hearing, speakers and/or headphones when you turn on the unit or start playing any source next time. REMEMBER you cannot adjust the volume level while the unit is on standby.

To turn down the volume level temporarily

Press FADE MUTING on the remote control. The volume level gradually decreases to "VOL MIN."

To restore the sound, press the button again.



Reinforcing the Bass Sound

This function only affects the playback sound, but does not affect your recording.

Turn the SUBWOOFER LEVEL control clockwise to increase the subwoofer sound or counterclockwise to decrease it.

- The subwoofer level can be adjusted in 4 steps (LEVEL 1 — LEVEL 4.)

If you turn the control clockwise up to the subwoofer LEVEL 4, "MAX" flashes on the display for a few seconds.

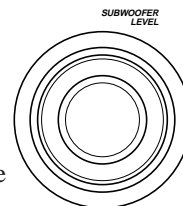

Subwoofer level can also be shown here

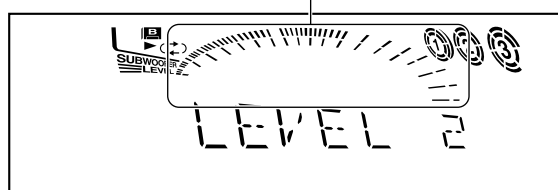

When using the remote control, press SUBWOOFER LEVEL + / -.

Selecting the Sound Modes

This function only affects the playback sound, but does not affect your recording.

You can select one of the 6 preset sound modes (3 surround modes and 3 SEA — Sound Effect Amplifier — modes).

To select the sound modes, turn the SOUND MODE control until the sound mode you want appears on the display.

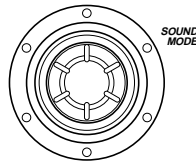

SOUND MODE indicator also lights up on the display

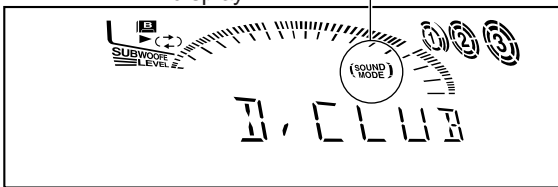

- As you turn the control, the sound modes change as follows:

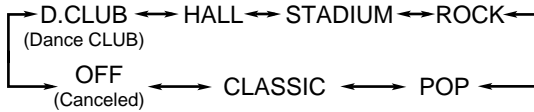

Surround modes*:

- D.CLUB:** Increases resonance and bass.
- HALL:** Adds depth and brilliance to the sound.
- STADIUM:** Adds clarity and spreads the sound, like in an outdoor stadium.

SEA (Sound Effect Amplifier) modes:

- ROCK:** Boosts low and high frequency. Good for acoustic music.
- POP:** Good for vocal music.
- CLASSIC:** Good for classical music.
- OFF:** Cancels the sound mode.

- * Surround elements are added to the SEA elements to create a being-there feeling in your room.

When one of these modes is selected, the SOUND MODE indicator lights up as — **(SOUND MODE)**

While one of the SEA modes (SEA elements without surround elements) is selected, the SOUND MODE indicator lights up as — **SOUND MODE**

When using the remote control, press SOUND MODE repeatedly.



- Each time you press the button, the sound modes change as follows:

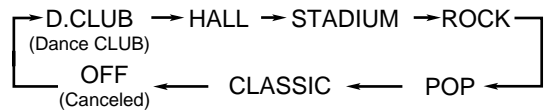

Creating a Being-There Feeling

By adding breadth and depth to the reproduced sounds, this function (3D Sound) can create a being-there feeling while playing back software encoded with Dolby Digital.

- When the “DIGITAL OUTPUT” setting is set to “BITSTREAM” (see page 29), this function does not work.

On the remote control ONLY:

Press 3D SOUND during play.

- Each time you press the button, 3D Sound turns on and off (and the current setting is shown on the TV screen).

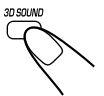

Listening to FM and AM Broadcasts

Tuning in a Station

1 Press FM/AM.

The unit automatically turns on and tunes in the previously tuned station (either FM or AM).

- Each time you press the button, the band alternates between FM and AM.



2 Start searching for stations.

On the unit:

Press and hold TUNING + or TUNING - for more than 1 second.

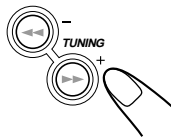

On the remote control:

Press and hold ►► or ◀◀ for more than 1 second.

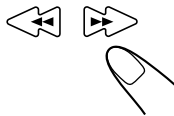

The unit starts searching stations and stops when a station of sufficient signal strength is tuned in.

- If a received program is broadcast in stereo, the ST (stereo) indicator lights up.

To stop during searching, press TUNING + or TUNING - (►► or ◀◀ on the remote control).



When you press TUNING + or TUNING - (or ►► or ◀◀ on the remote control) briefly and repeatedly

The frequency changes step by step.

To change the FM reception mode

When an FM stereo broadcast is hard to receive or noisy, press FM MODE/SLOW on the remote control so that “MONO” appears and the MONO indicator also lights up on the display. Reception improves.



To restore the stereo effect, press FM MODE/SLOW again so that “STEREO” appears on the display and the MONO indicator goes off from the display.

In this stereo mode, you can hear stereo sounds when a program is broadcast in stereo.

Presetting Stations

You can preset 30 FM and 15 AM stations.

In some cases, test frequencies have been already memorized for the tuner since the factory examined the tuner preset function before shipment. This is not a malfunction. You can preset the stations you want into memory by following the presetting method.

- There is a time limit in doing the following steps. If the setting is canceled before you finish, start from step 2 again.

On the unit ONLY:

1 Tune in the station you want to preset.

- See “Tuning in a Station” on the left column.

FM 87.50

2 Press SET.

SET

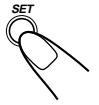

3 Press PRESET + or PRESET - to select a preset number.

P 01

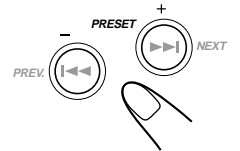

4 Press SET again.

STORED

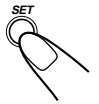

The tuned station in step 1 is stored in the preset number selected in step 3.

- Storing a new station on a used number erases the previously stored one.



When you unplug the AC power cord or if a power failure occurs

The preset stations will be erased in a few days. If this happens, preset the stations again.

Tuning in a Preset Station

1 Press FM/AM.

The unit automatically turns on and tunes in the previously tuned station (either FM or AM).

- Each time you press the button, the band alternates between FM and AM.



2 Select a preset number.

On the unit:

Press PRESET + or PRESET -.

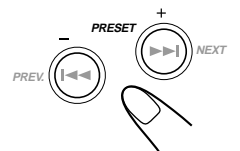

On the remote control:

Press the number buttons.

Ex.: For preset number 5, press 5.

For preset number 15, press 10, then 5.

For preset number 20, press 10 twice (and wait for a few seconds.)

For preset number 30, press 10 three times (and wait for a few seconds.)

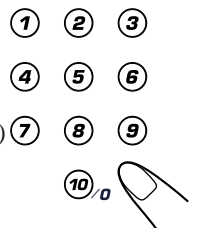

Disc Introduction—DVD/VCD/CD

This unit has been designed to play back the following discs: DVD, Video CD, Audio CD, CD-R, and CD-RW.

Discs you can play:

Disc Type	Mark (Logo)	Video Format	Region Code Number*
DVD Video		NTSC	1 ALL
Video CD			_____
Audio CD			_____
CD-R			_____
CD-RW			_____

- On some DVD or VCD discs, their actual operations may be different from what is explained in this manual. This is due to the disc programming and disc structure, but not a malfunction of this unit.
- The following discs cannot be played back;
 - DVD-Audio, DVD-ROM, DVD-RAM, DVD-R, DVD-RW, CD-ROM, CD-I, (CD-I Ready), Photo CD, etc.
 Playing back these discs will generate noise and damage the speakers.

* Note on Region Code

DVD players and DVD Video discs have their own Region Code numbers. This unit only can play back DVD discs recorded with the color system of NTSC whose Region Code numbers include “1.”

Examples:



IMPORTANT: Before performing any operations, make sure of the following....

- Check the connection with the TV.
- Turn on the TV and select the correct input on the TV to view the pictures or on-screen indications on the TV screen.
- For DVD playback, you can change the Setup menu setting to your preference. (See pages 28 – 30.)

If “ INVALID” appears on the TV screen when pressing a button, the disc cannot accept the operation you have tried to do.

Disc structure — DVD, Video CD (VCD) and Audio CD (CD)

A DVD disc consists of **Titles**, and each title may be divided into some **Chapters**. (See Example 1.)

For example, if a DVD disc contains some movies, each movie may have its own title number, and it may be further divided into some chapters.

On the other hand, a VCD or CD consists of **Tracks**. (See Example 2.)

In general, each song has its own track number. (On some discs, each track may also be divided by Indexes.)

When playing back a VCD with Playback Control (PBC) function, you can select what to view using the menu shown on the TV screen. (While operating a Video CD using the menu, some of the functions such as Repeat and Variable Speed Search may not work.)

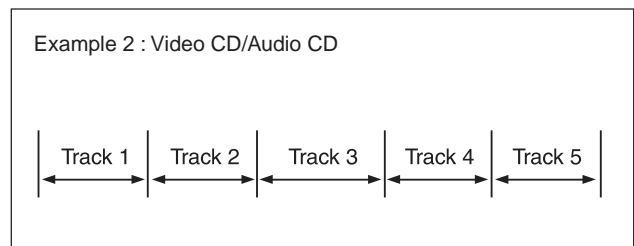
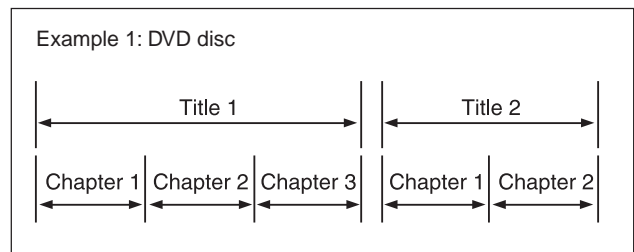

Note on CD-R and CD-RW

User-edited CD-Rs (Recordable) and CD-RWs (Rewritable) can be played back only if they are already “finalized.”

- The player can play back CD-Rs or CD-RWs recorded on a personal computer only if it has been recorded in the audio CD format. (However, they may not be played back depending on their characteristics or recording conditions.)
- Before playing back CD-Rs or CD-RWs, read their instructions or cautions carefully.
- Some CD-Rs or CD-RWs may not be played back on this unit because of their disc characteristics, damage or stain on them, or if the player’s lens is dirty.
- CD-RWs may require a longer readout time. This is caused by the fact that the reflectance of CD-RWs is lower than for regular CDs.

Basic Disc Operations

Loading Discs

1 Press **▲**.

The unit automatically turns on and the carousel comes out.



2 Place one or two discs correctly on the front slots of the carousel, with its label side up.

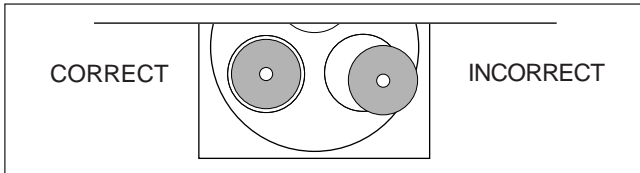

- When using a CD single (8 cm), place it on the inner circle of the disc tray.
- Continued use of irregular shape CDs (heart-shape, octagonal, etc.) can damage the unit.

3 If you wish to load a third disc, press **DISC CHANGE** on the unit or **DISC SKIP** on the remote control.

The carousel rotates by 120°.



4 Press **▲** again.

The carousel closes.



About the disc indicators

Each disc indicator corresponds to the disc tray of the same number.

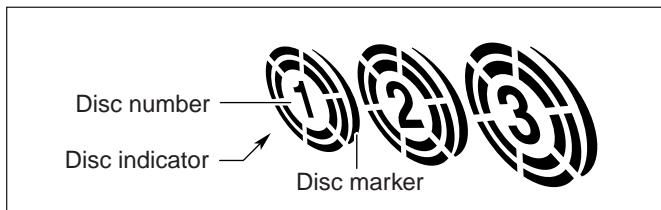

- The disc marker lights up for the disc number you have selected.
- The disc indicator rotates while the corresponding disc is being played.
- The disc indicator goes off when the unit has detected that there is no disc on the corresponding disc tray.

Playing Back Discs

You can play a disc(s).

- If a menu appears while playing a DVD or VCD with PBC function, see page 19 (for DVD) or page 23 (for VCD).

1 Load a disc(s).

2 Press one of the disc number buttons (DVD1, DVD2, and DVD3) for the disc you want to play.

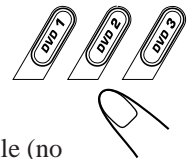

“WAIT” appears on the display for a while (no operations will be accepted during this period), then disc play starts from the first chapter or track of the selected disc.

■ When playing a DVD:

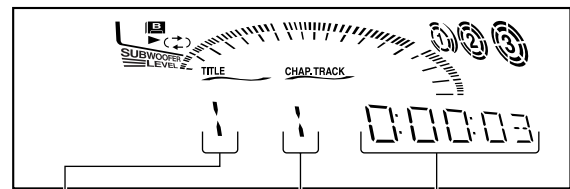

Title No. Chapter No. Elapsed playing time

■ When playing other discs:

Lights up when a VCD with PBC is played

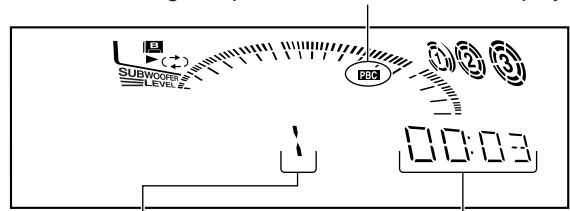

Track No. Elapsed playing time

- Pressing DVD **▶/||** instead of the disc number buttons starts playing back if a disc is on the trays.

To stop during play, press **■.** (If your TV is turned on, “**■ PRESTOP**” appears on the TV screen.)

- This unit can memorize the end point. When you start playback again by pressing DVD **▶/||**, playback begins from where it has been stopped unless you change the source or turn off the unit. (Resume play)
- **To stop completely, press **■** twice (“**■ STOP**” appears on the TV screen.)**

To remove the disc, press **▲.**



When playing back CDs and VCD without PBC function, all loaded discs can be played continuously

When 3 discs are loaded on the disc trays, they are played in one of the following sequences.

- When DVD1 is pressed : DVD1 ⇒ DVD2 ⇒ DVD3 (then stops)
- When DVD2 is pressed : DVD2 ⇒ DVD3 ⇒ DVD1 (then stops)
- When DVD3 is pressed : DVD3 ⇒ DVD1 ⇒ DVD2 (then stops)
- When only 2 discs are loaded, they are played in the same order, but the disc tray without a disc is skipped.
- If you change discs during play (see below), the current play will not stop until all discs you have changed are played.



If “PARENTAL LEVEL” appears on the TV screen

Parental Lock is in use. You cannot play back a DVD containing violent scenes or those not suitable for your family members. To play back such a disc, cancel the Parental Lock. (See page 30)

To exchange discs during playback of another disc

Press DISC CHANGE to change the disc and the carousel comes out.

To close the carousel, press DISC CHANGE or



To skip to another disc in the carousel

Press DISC SKIP on the remote control.

- Pressing DVD1, DVD2, or DVD3 will also skip to the selected disc tray.



To stop play for a moment

Press DVD (or STILL) while playing a disc.

While pausing, the elapsed playing time stops being counted and starts flashing. (If your TV is turned on, “ PAUSE” also appears on the TV screen.)

- A still picture appears while playing a DVD or VCD. You can advance the still picture frame by frame by pressing the STILL on the remote control repeatedly. (See page 22 or 27.)



To resume play, press DVD again.

To go to another chapter or track

Press or repeatedly before or during playback.

- : Goes back to the beginning of the previous chapter or track.
- : Skips to the beginning of the next or succeeding chapter or track.

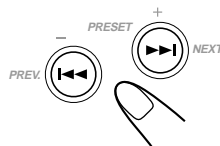

To go to another chapter or track directly using the number buttons

Pressing the number buttons before or during play allows you to start playing the chapter or track number you want.

- To select number 1 to 9, simply press the corresponding number button, and wait for a few seconds.
- To select number 10, press 1, 0.
- To select number 23, press 2, 3.

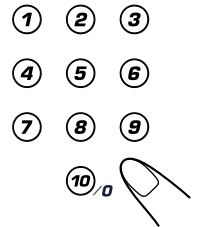

Prohibiting Disc Ejection—Tray Lock

You can prohibit disc ejection from the unit and can lock discs.

- This operation is possible only while the unit is on with disc selected as the source.

On the unit ONLY:

To prohibit disc ejection, press while holding .

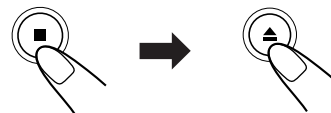

“LOCKED” appears for a while, and the carousel is locked.

To cancel the prohibition and unlock the discs, press while holding .

“UNLOCKED” appears for a while, and the carousel is unlocked.





If you try to eject discs

“LOCKED” appears to inform you that the Tray Lock is in use.

DVD Playback

Some DVDs contain several audio languages, subtitles, and multi-angle views.

When you find the following marks on the DVD or its package, you can select these elements recorded on the DVD.

	<p>Subtitles are recorded on the disc. The number inside the mark indicates the total number of the recorded subtitles.</p>
	<p>Several audio languages are recorded on the disc. The number inside the mark indicates the total number of the recorded audio languages.</p>
	<p>Multi-angle views are recorded on the disc. The number inside the mark indicates the total number of the recorded multi-angle views.</p>

If you cannot find out whether your disc contains these features listed above, you can check it by showing the on-screen bar.

For basic disc operations such as inserting discs, starting playback, and moving to another chapters, see “Basic Disc Operations” on pages 15 and 16.

Showing the On-Screen Bar

You can show the following information on the TV screen while a disc is loaded.

On the remote control ONLY:

To show the disc information, press **ON SCREEN**.



- Each time you press the button, the following on-screen bar appears in sequence.

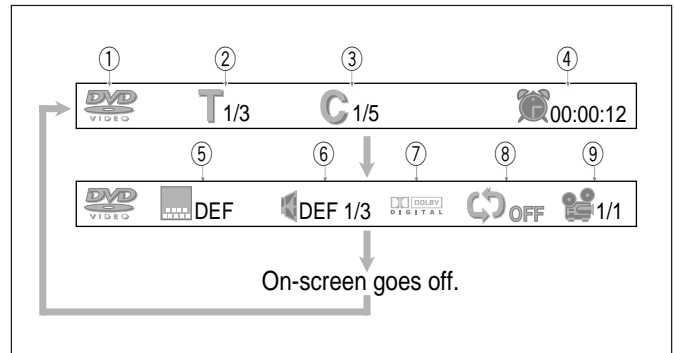

① : Disc type
② : Current title and total number of the titles on the disc <ul style="list-style-type: none"> • Ex.: 1st title is playing out of 3 titles recorded.
③ : Current chapter and total number in the current title <ul style="list-style-type: none"> • Ex.: 1st chapter is playing out of 5 chapters in the current title.
④ : Elapsed playing time of the current title
⑤ : Subtitle language indication <ul style="list-style-type: none"> • Ex.: When no subtitle is recorded on the disc. See page 18 for more details.
⑥ : Audio language indication <ul style="list-style-type: none"> • Ex.: Original sound (default) is selected out of 3 audio languages recorded. See page 18 for more details.
⑦ : Signal format indicator <ul style="list-style-type: none"> • Signal format type—Linear PCM (stereo), Dolby Digital, and DTS Digital Surround—will be indicated Ex.: When the disc is encoded with Dolby Digital.
⑧ : Repeat mode indicator <ul style="list-style-type: none"> • Ex.: When repeat mode is turned off. See page 20 for more details.
⑨ : Multi-angle view indicator <ul style="list-style-type: none"> • Ex.: When only single angle-view is recorded on the disc. See page 18 for more details.

Selecting the Subtitles

While playing a disc containing subtitles in different languages, you can select the subtitle to be displayed on the TV screen.

- You can set your favorite subtitle language as the initial language shown on the TV screen. (See page 28.)

On the remote control ONLY:

To select the subtitle language, press **SUBTITLE** repeatedly.



The on-screen bar appears on the TV screen.

- Each time you press the button, the subtitle language changes.

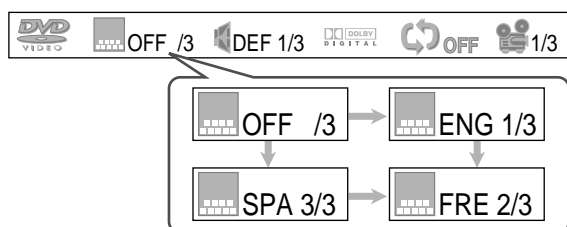

Ex.: When the disc has 3 selections — English, French, Spanish and no subtitle (OFF)

Selecting the Audio Languages

While playing a disc containing audio languages (sound tracks), you can select the audio language (sound track) to listen to.

- You can set your favorite audio language as the initial audio language. (See page 28.)

On the remote control ONLY:

To select the subtitle language, press **AUDIO** repeatedly.



The on-screen bar appears on the TV screen.

- Each time you press the button, the audio language changes.

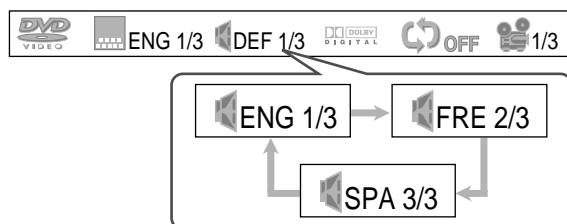

Ex.: When the disc has 3 selections—English, French, and Spanish

Selecting the Multi-Angle Views

While playing a disc containing multi-angle views, you can view the same scene at different angles.

On the remote control ONLY:

To select the subtitle language, press **ANGLE** repeatedly.



- Each time you press the button, the view angle changes.

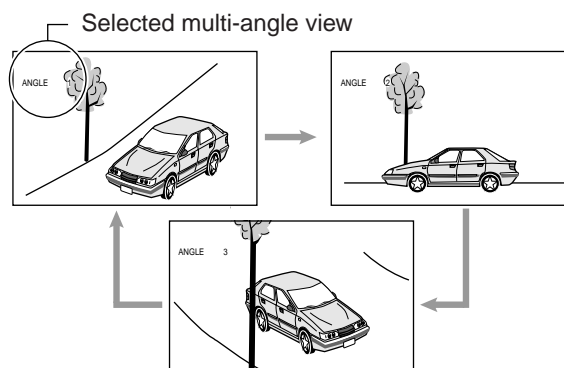

Ex.: When the disc has 3 multi-angle views



When the on-screen bar is shown on the TV screen Multi-angle view indication also changes as follows:

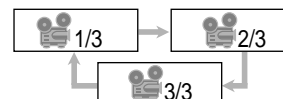

Disc Menu-Driven Playback

Disc menu-driven playback is possible while playing back a DVD with menus.

- When operating a disc using the disc menu, refer also to the instructions supplied with the disc.

DVD discs generally have their own menus or title lists. A menu usually contains various information about the disc and playback selections. On the other hand, a title list usually contains titles of movies and songs recorded.

On the remote control ONLY:

1 Press MENU/PBC or TITLE.

A menu or title list will appear on the TV screen.

- On some DVDs, a menu will automatically appear on the TV screen.

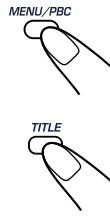

2 Select a desired item on the menu or on the title list, using Cursor buttons (▲/▼/▶/◀) and ENTER.

The unit starts playback of the selected item.

- On some discs, you can also select items by pressing the number buttons corresponding to the item numbers listed.

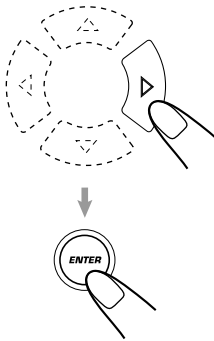

- If “⊗ INVALID” appears on the TV screen when pressing MENU/PBC in step 1, the disc does not have a menu.
- If “⊗ INVALID” appears on the TV screen when pressing TITLE in step 1, the disc does not have a title list.

Moving to a Particular Portion Directly

You can move to another title, chapter, or particular scene in the chapter directly.

On the remote control ONLY:

1 Press GO TO during play or pause.

- Each time you press the button, the following indication appears on the TV screen.

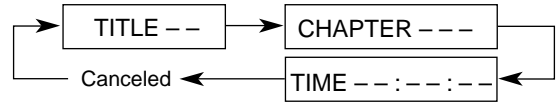

TITLE -- : Select this to move to another title.

CHAPTER --- : Select this to move to another chapter.

TIME --:--:-- : Select this to move to a particular scene.

2 Press the number buttons to select a desired title, chapter, or playing time.

The unit starts playback of the selected item. (The on-screen bar appears for a while.)

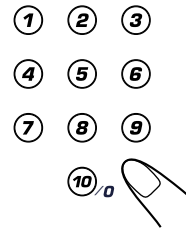

How to input the title and chapter number

Press the number buttons corresponding to the number, then wait for about 5 seconds or press ENTER to start playback.

- To select number 5, press 5.
- To select number 10, press 1, 0.
- To select number 23, press 2, 3.

How to input the playing time

Press the number buttons to input the playing time, then wait for about 5 seconds or press ENTER to start playback at the selected elapsed playing time.

- To input time “00:45:23,” press 4, 5, 2, 3.
- To input time “01:23:45,” press 1, 2, 3, 4, 5.
- To cancel a mis-entry, press CLEAR.

Each time you press the button, the last entry will be erased.



When you want to go to another chapter directly

By simply pressing the number button, you will move to the selected chapter.

Searching for a Particular Point

You can search for a particular portion while playing a disc—Variable Speed Forward/Reverse Search.

- No sound comes out during Variable Speed Forward/Reverse Search.

■ Variable Speed Forward Search

To fast-forward the chapter, press **▶▶** during play.

- Each time you press the button, the search speed changes as follows:

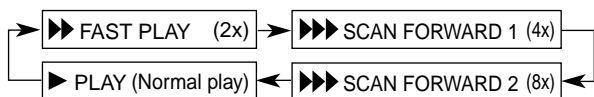

■ Variable Speed Reverse Search

To reverse the chapter, press **◀◀** during play.

- Each time you press the button, the search speed changes as follows:

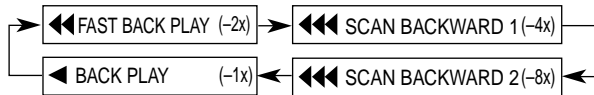

To resume normal play

Press DVD **▶/||**.

Repeating Playback

■ Repeat Play

To repeat playback, press REPEAT repeatedly during play.

- Each time you press the button, repeat mode changes as follows:

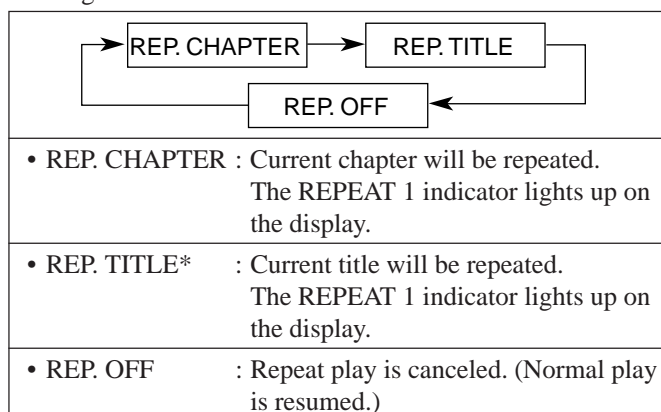

* Cannot be selected during program play.



When the on-screen bar is shown on the TV screen

Repeat mode indication also changes as follows:

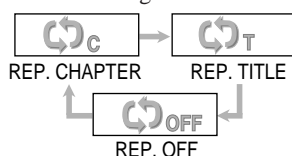

■ A-B Repeat

While playing, you can also select a portion you want to repeat.

- A-B repeat is not performed between different titles.

Example:

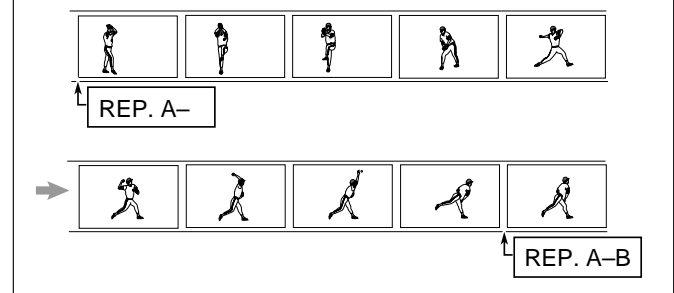

1 Press A-B REPEAT to select the start point.

“RPT. A-” appears on the TV screen.

- “RPT A-” also appears on the display.

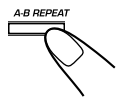

2 Press A-B REPEAT again to select the end point.

“RPT. A-” changes to “RPT. A-B,” then A-B repeat begins.

The unit automatically locates point A and starts repeating

the portion between points A and B.

- “RPT A-B” also appears on the display.

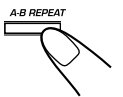

To cancel A-B Repeat, press A-B REPEAT again. “RPT. OFF” appears on the TV screen.



When the on-screen bar is shown on the TV screen Repeat mode indication also changes as follows:

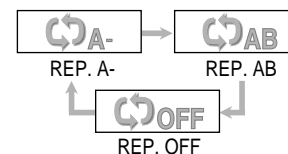

If “**⊘ INVALID**” appears on the TV screen when pressing A-B REPEAT in step 1, A-B repeat cannot be used on the selected portion.

- On some DVDs, A-B repeat may not be used even within the same title. This is due to their disc structures, but not a malfunction of the unit.

Programming the Playing Order of the Chapters—Program Play

You can arrange the chapter playback order before you start playing. You can program up to 20 steps.

- Before making a program, make sure that the TV is turned on and the correct input is selected on the TV.

On the remote control ONLY:

1 Load a disc.

- If the current playing source is not the DVD player, press DVD1, DVD2 or DVD3 on the unit to select the disc you want to play, then **■** before going to the next step.

2 Press PLAY MODE.

The PROGRAM MENU screen appears on the TV screen.

- Each time you press the button, program mode turns on and off.

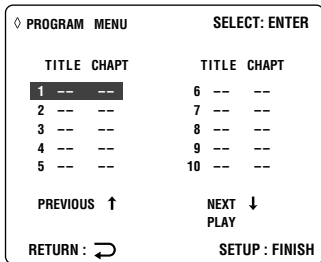

3 Press ENTER.

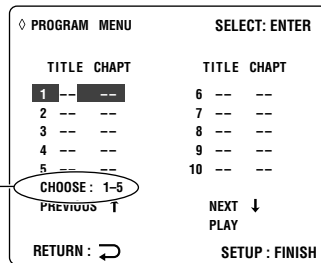

Title numbers you can select in the next step

4 Press Cursor ► or ◀ (or number button) to select a title number, then ENTER.

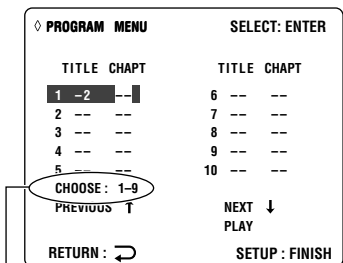

Chapter numbers you can select in the next step

5 Press Cursor ► or ◀ (or number button) to select a chapter number, then ENTER.

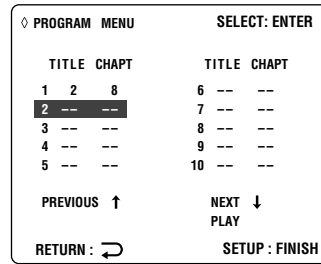
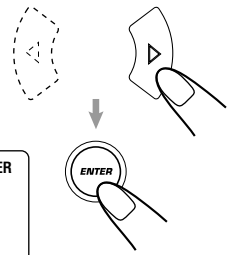

- To select all chapters in the selected title as one program step, simply press ENTER without selecting any number. “ALL” appears on the chapter number position.

6 Repeat steps 4 and 5 to program other chapters you want.

- After 10 steps are programmed, “NEXT ↓” is selected (highlighted). If you want to program more steps, press ENTER.

7 Press DVD ►/||.

The chapters are played in the order you have programmed.



To stop during play, press **■**.

The PROGRAM MENU screen appears on the TV screen.

- If you press DVD ►/|| while this screen is shown, the unit starts program play.

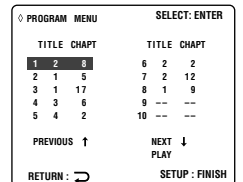

To exit from program mode, press PLAY MODE.

The PROGRAM MENU screen goes off, and the opening screen appears. (The program you made is still kept in memory.)



- If you press DVD ►/|| while this screen is shown, the unit starts normal playback.

To erase the stored program, eject the carousel by pressing **▲**.

- If you perform the following operations, the program is also erased—turning off the unit, changing the source, or skipping a disc.

To check the programmed contents

You can check the programmed contents by pressing PLAY MODE. The PROGRAM MENU screen appears on the TV screen.

- If you press the button during play, the program play will stop.

To modify the program

You can modify the program while the PROGRAM MENU screen is shown on the TV screen.

To erase a step: press Cursor ▼ (or ▲) to select (highlight) an unwanted program step, then press CLEAR.

To modify a step: press Cursor ▼ (or ▲) to select (highlight) a program step you want to modify, then perform steps 4 to 5 on page 21. (Before entering a new number, press CLEAR repeatedly until “-” appears on number entry position.)

To add a step: press Cursor ▼ (or ▲) to select (highlight) an empty program step, then perform steps 4 and 5 on page 21.

- To move program step 11 to program step 10, press Cursor ▲ when program step 11 is selected (highlighted) so that “PREVIOUS ↑” is selected (highlighted). Then, press ENTER.
- To move program step 10 to program step 11, press Cursor ▼ when program step 10 is selected (highlighted) so that “NEXT ↓” is selected (highlighted). Then, press ENTER.

DVD Special Effect Playback

■ Still Picture/Frame-by-Frame Playback

You can advance the still picture frame by frame while playing a DVD.

On the remote control ONLY:

1 Press STILL (or DVD ►/||) once during play.

A still picture appears on the TV screen.

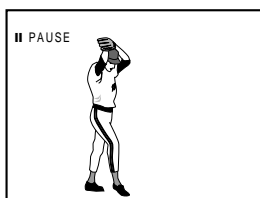

2 Press STILL repeatedly to advance the picture frame by frame.

- Each time you press the button, the picture advances frame by frame.



To resume normal play

Press DVD ►/||.

■ Slow Motion Playback

You can enjoy slow motion playback while playing a DVD.

On the remote control ONLY:

Press FM MODE/SLOW repeatedly during play.

- Each time you press the button, slow motion speed changes as follows:

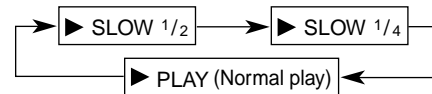

■ Zoom

You can zoom in on the picture while playing a DVD.

On the remote control ONLY:

1 Press ZOOM to zoom in.

- Each time you press the button, the picture is enlarged as follows:

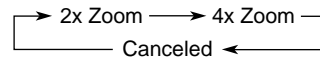
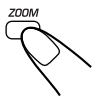

2 Press Cursor (◀, ▶, ▲, ▼) to move the enlarged portion you want to watch.

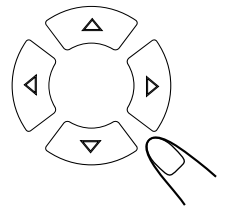

To cancel the Zoom, press ZOOM repeatedly until the normal size picture is resumed.

VCD/CD Playback

For basic disc operations such as inserting discs, starting playback, and moving to another tracks, see “Basic Disc Operations” on pages 15 and 16.

Showing the On-Screen Bar

You can show the following information on the TV screen while a disc is loaded.

On the remote control ONLY:

To show the disc information, press **ON SCREEN**.



- Each time you press the button, the following on-screen bar appears and disappears alternately.

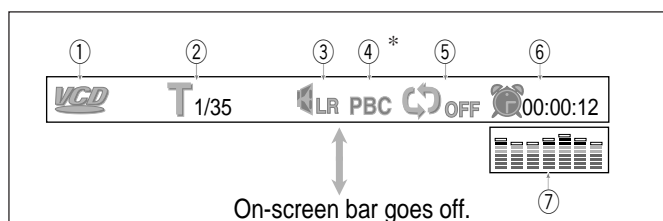

* Appears only when a VCD is loaded.

①: Disc type
②: Current track and total number of the tracks on the disc • Ex.: 1st track is playing out of 35 tracks recorded.
③: Sound mode • Ex.: Stereo sound (Left channel and Right channel)
④: Play Back Control (PBC) indicator • Ex.: PBC is on. (When PBC is turned off, will appear.)
⑤: Repeat mode indicator • Ex.: When repeat mode is turned off. See page 25 for more details.
⑥: Elapsed playing time of the current track
⑦: Spectrum analyzer • Indicates sound input level. (Appears only during play.)

Disc Menu-Driven Playback (Only for VCD)

The Playback Control function (PBC) allows you to operate the VCD using disc menus.

When you start playing a VCD with PBC function, a disc menu will automatically appear on the TV screen.

- A menu may be a list of items, divided screens, or some moving pictures. (See “PBC operation concept” on the right column.)

When a menu appears, select a desired item on the disc menu.

- When a list of items is displayed on the screen, press the number buttons to select an item. (To use the number buttons, see “To go to another chapter or track directly using the number buttons” on page 16.)
- When “▶” or “SELECT” is displayed on the TV screen, press DVD ▶/|| to start playback.
- When operating a disc using the disc menu, refer also to the instructions supplied with the disc.

To go to the next menu

Press NEXT.

To return to the previous menu

Press PREV. or RETURN.

To cancel the PBC playback

You can cancel the menu-driven operations (PBC function):

- 1 Press to stop playback.
 - 2 Press the number buttons to select a track.
Normal playback starts from the selected track.
- You can also turn on and off the PBC function by pressing MENU/PBC on the remote control. Each time you press the button, the PBC function turns on and off.

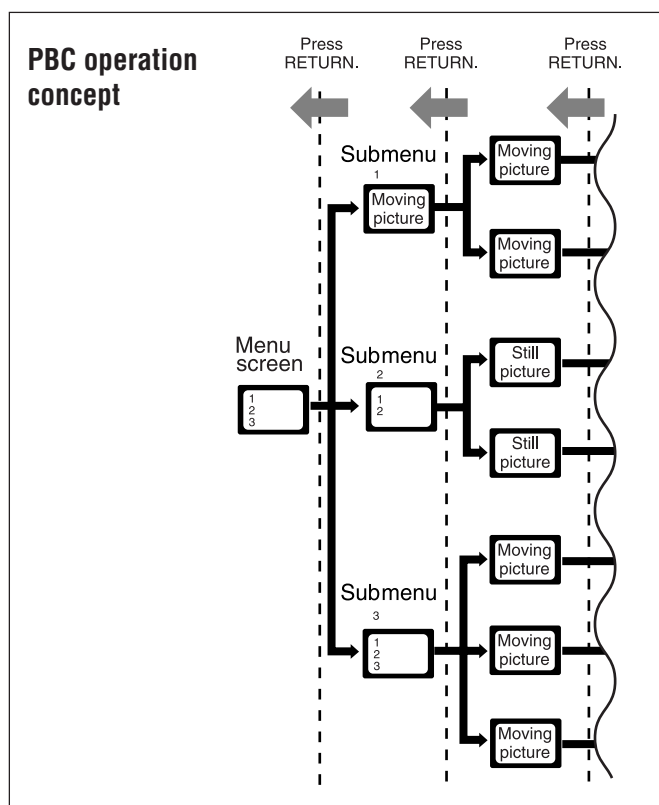

While operating a Video CD using the menu
Some of the functions such as Repeat and Variable Speed Search may not work.

Moving to a Particular Portion Directly

You can move to a particular portion in the track directly.

On the remote control ONLY:

1 Press GO TO during play or pause.

- Each time you press the button, the following indication appears on the TV screen.

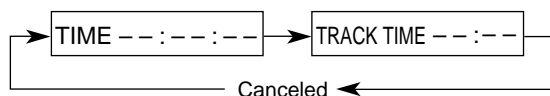

TIME --:--:--

: Select this to move to a particular portion of the current disc.

TRACK TIME --:--:--

: Select this to move to a particular portion on the current track.

2 Press the number buttons to select a playing time you want to search for.

The unit starts playback at the selected elapsed playing time. (The on-screen bar appears for a while.)

① ② ③

④ ⑤ ⑥

⑦ ⑧ ⑨

⑩ 0 

- To input time “45:23,” press 4, 5, 2, 3, then wait for about 5 seconds (or press ENTER).
- To input time “09:45,” press 9, 4, 5, then wait for about 5 seconds (or press ENTER).
- To cancel a mis-entry, press CLEAR. Each time you press the button, the last entry will be erased.

Searching for a Particular Point

You can search for a particular portion while playing a disc—Variable Speed Forward/Reverse Search.

- No sound comes out during Variable Speed Forward/Reverse Search on a VCD.

Variable Speed Forward Search

To fast-forward the track, press  during play.

- Each time you press the button, the search speed changes as follows:

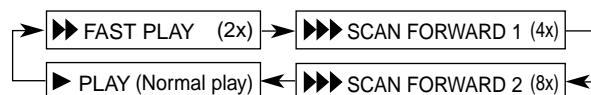

Variable Speed Reverse Search

To reverse the track, press  during play.

- Each time you press the button, the search speed changes as follows:

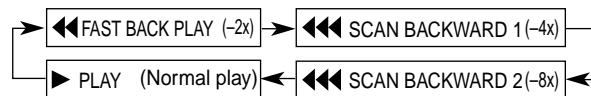

Repeating Playback

Repeat Play

- Repeat play cannot be used on a VCD with the PBC function.

To repeat playback, press REPEAT repeatedly during play.

- Each time you press the button, repeat mode changes as follows:

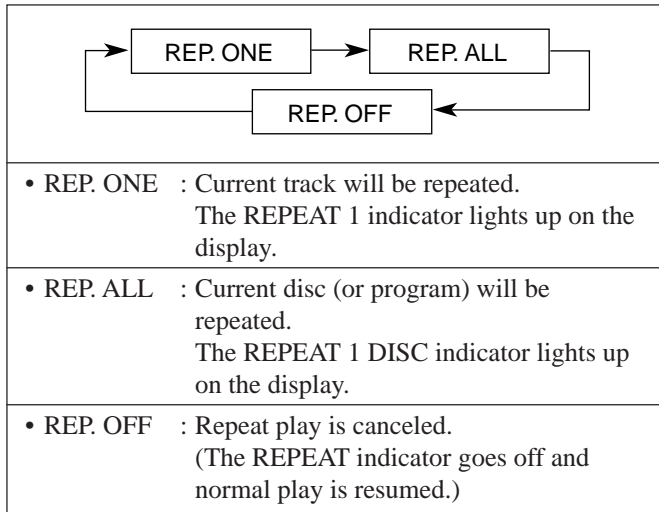

When the on-screen bar is shown on the screen

Repeat mode indication also changes as follows:

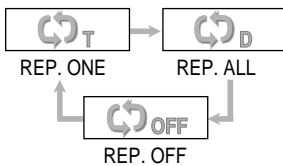

A-B Repeat

While playing, you can also select a portion you want to repeat.

- A-B repeat may not be used on some VCDs with the PBC function.

Example:

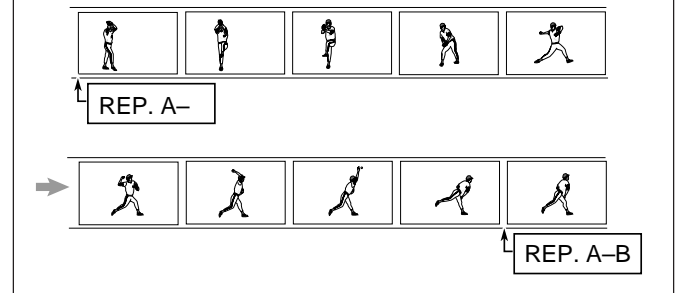

1 Press A-B REPEAT to select the start point.

“RPT. A-” appears on the TV screen.

- “RPT A-” also appears on the display.



2 Press A-B REPEAT again to select the end point.

“RPT. A-” changes to “RPT. A-B,” then A-B repeat begins.

The unit automatically locates point A and starts repeating the portion between points A and B.

- “RPT A-B” also appears on the display.

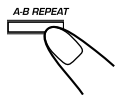

To cancel A-B Repeat, press A-B REPEAT again.

“RPT. OFF” appears on the TV screen.



When the on-screen bar is shown on the TV screen

Repeat mode indication also changes as follows:

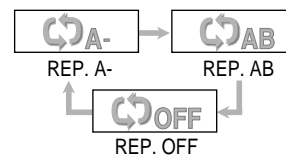

Programming the Playing Order of the Tracks—Program Play

You can arrange the track playback order before you start playing. You can program up to 20 steps.

- Before making a program, make sure that the TV is turned on and the correct input is selected on the TV.

On the remote control ONLY:

1 Load a disc.

- If the current playing source is not the DVD player, press DVD1, DVD2 or DVD3 on the unit to select the disc you want to play, then  before going to the next step.

2 Press PLAY MODE.

The PROGRAM MENU screen appears on the TV screen.

- Each time you press the button, program mode turns on and off.

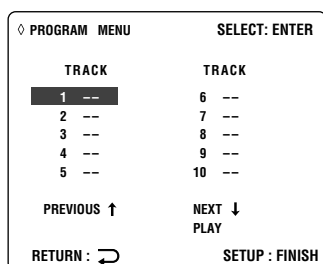

3 Press ENTER.

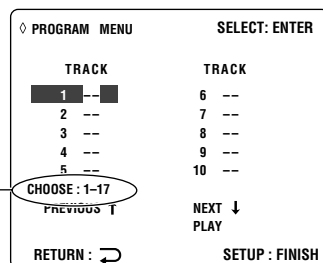

Track numbers you can select in the next step

4 Press Cursor or (or number button) to select a track number, then ENTER.

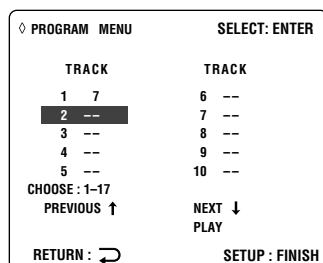

5 Repeat step 4 to program other tracks you want.

- After 10 steps are programmed, “NEXT ↓” is selected (highlighted). If you want to program more steps, press ENTER.

6 Press DVD .

The tracks are played in the order you have programmed.



To stop during play, press .

The PROGRAM MENU screen appears on the TV screen.

- If you press DVD  while this screen is shown, the unit starts program play.

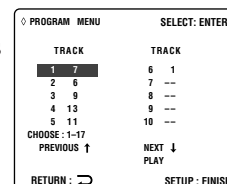

To exit from program mode, press

PLAY MODE.

The PROGRAM MENU screen goes off, and the opening screen appears. (The program you made is still kept in memory.)

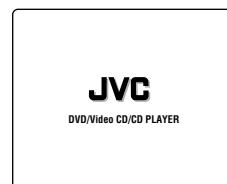

- If you press DVD  while this screen is shown, the unit starts normal playback.

To erase the stored program, eject the carousel by pressing



- If you perform the following operations, the program is also erased—turning off the unit, changing the source, or skipping a disc.

To check the programmed contents

You can check the programmed contents by pressing PLAY MODE. The PROGRAM MENU screen appears on the TV screen.

- If you press the button during play, the program play will stop.

To modify the program

You can modify the program while the PROGRAM MENU screen is shown on the TV screen.

To erase a step: press Cursor ▼ (or ▲) to select (highlight) an unwanted program step, then press CLEAR.

To modify a step: press Cursor ▼ (or ▲) to select (highlight) a program step you want to modify, then perform step 4 on page 26. (Before entering a new number, press CLEAR repeatedly until “- -” appears on number entry position.)

To add a step: press Cursor ▼ (or ▲) to select (highlight) an empty program step, then perform step 4 on page 26.

- To move program step 11 to program step 10, press Cursor ▲ when program step 11 is selected (highlighted) so that “PREVIOUS ↑” is selected (highlighted). Then, press ENTER.
- To move program step 10 to program step 11, press Cursor ▼ when program step 10 is selected (highlighted) so that “NEXT ↓” is selected (highlighted). Then, press ENTER.

VCD Special Effect Playback

■ Still Picture/Frame-by-Frame Playback

You can advance the still picture frame by frame while playing a VCD.

On the remote control ONLY:

1 Press **STILL** (or DVD ►/||) once during play.

A still picture appears on the TV screen.

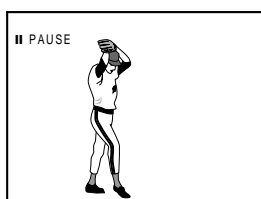

2 Press **STILL** repeatedly to advance the picture frame by frame.

- Each time you press the button, the picture advances frame by frame.



To resume normal play

Press DVD ►/||.

■ Slow Motion Playback

You can enjoy slow motion playback while playing a VCD.

On the remote control ONLY:

Press **FM MODE/SLOW** repeatedly during play.

- Each time you press the button, slow motion speed changes as follows:

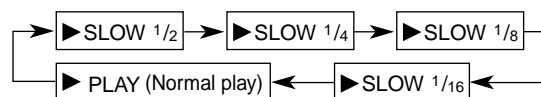

■ Zoom

You can zoom in on the picture while playing a VCD.

On the remote control ONLY:

1 Press **ZOOM** to zoom in.

- Each time you press the button, the picture is enlarged and resumed.



2x Zoom ↔ Canceled

2 Press Cursor (◀, ▶, ▲, ▼) to move the enlarged portion you want to watch.

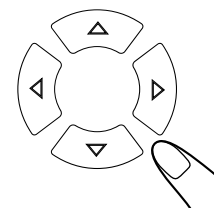

To cancel the Zoom, press ZOOM again so that the normal size picture is resumed.

On the Setup menu, you can perform two important settings—language selection (LANGUAGE) and system setting (SYSTEM).

- Setup menu can only be displayed while a disc is not playing. (The DVD player must be selected as the playback source.)
- You can only use the remote control for Setup menu operations.

Setting the Initial Languages

You can select your favorite language you listen to or read on the TV screen. When you operate this unit or watch a DVD, you will be able to operate the unit or to enjoy a DVD in the language you have selected.

On the language selection menu, you can select the following:

OSD LANGUAGE	: Select the Setup menu language shown on the TV screen.
AUDIO	: Select the audio language you listen to while watching a DVD.
SUBTITLE	: Select the subtitle language you read while watching a DVD.
MENU LANGUAGE	: Select the disc menu language recorded a DVD which you use while operating a DVD's own menu.

Languages you can select on this menu

You can select the following languages separately for each listed item on the menu.

- For **“OSD LANGUAGE”**: English, Chinese, Spanish, French, German, Japanese, and Korean.
- For **“AUDIO,” “SUBTITLE,” and “MENU LANGUAGE”**: English, Chinese, French, German, Japanese, Russian, Spanish, Portuguese, Korean and Original*.

* Available only for “AUDIO” and “SUBTITLE.” When you want to operate the disc or enjoy its playback in the originally recorded (default) language, select “ORIGINAL.”



The original language will be selected as the initial language regardless of your setting in the following cases

- If the language you have selected is not recorded on the disc.
- If the disc is programmed to be played back in the original language.

Language selecting procedure

Ex.: To select “FRENCH” as the initial language for “AUDIO.”

1 Press SETUP.

Language selection menu appears on the TV screen.

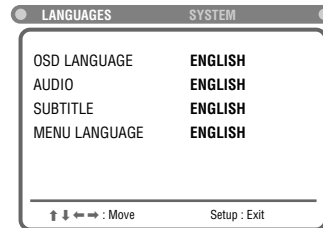

2 Press Cursor ▼ (or ▲) to select (highlight) one of the language items.

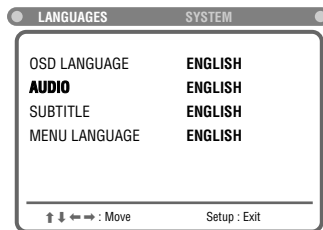
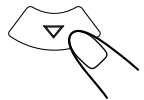

3 Press ENTER.

Pop-up window appears (where the language names are listed).



✓ indicates the current setting.

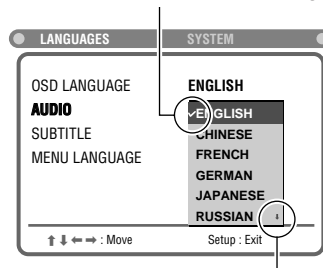

↓ indicates that more languages are listed, but not shown.

4 Press Cursor ▼ (or ▲) to select (highlight) the language you want, then press ENTER.



The setting is stored (and the pop-up window goes off).

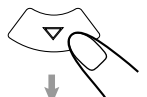

To cancel the setting you have just made, press RETURN without pressing ENTER. (Pop-up menu also goes off.)



5 Repeat steps 3 and 4 to select the other language items listed.

To erase the Setup menu, press SETUP.

Setting the DVD Preference (System)



You can set the DVD preference to match it to your usage and operating circumstances.

On the system setting menu, you can set the following:

VIDEO OUTPUT : You can select the video output jack on the rear to use.

- **YUV** : Select when you connect your TV to the VIDEO output jack.
- **S-VIDEO** : Select when you connect your TV to the S-VIDEO output jack.

TV SCREEN : Select the TV screen size for playing back a DVD recorded with 16:9 wide screen video signal.

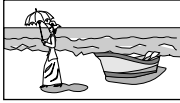
- **4:3 LB (Letter Box)**: Select when the aspect ratio of your TV is 4:3. While viewing a wide screen picture, the black bars on the top and the bottom of the screen. 
- **4:3 PS (Pan-Scan)**: Select when the aspect ratio of your TV is 4:3. While viewing a wide screen picture, the black bars do not appear, however, the left and right edge sides of the pictures will not be shown on the screen. 
- **16:9 WIDE** : Select when the aspect ratio of your TV is 16:9. 

- **Even if “4:3 PS” is selected**, the screen size may become “4:3 LB” while playing some DVDs. This depends on how the DVD is programmed and recorded.
- **If a disc (or some portions of the disc) is recorded with the video signals of 4:3 aspect ratio**, this setting does not take effect. The pictures are displayed with full 4:3 aspect ratio or with 4:3 Letter Box.

RATING LEVEL : You can select this to restrict playback of DVD containing violent scenes and those not suitable for your family members. (See page 30 for detailed operations.)

DIGITAL OUTPUT : You can select the format of digital signals output through the DIGITAL OUT (OPTICAL) terminal. (See page 39 for detailed information.)

- **BITSTREAM**: Select when connecting an amplifier or a decoder compatible with Dolby Digital and with DTS Digital Surround.
- **LPCM** : Select when connecting an amplifier or a decoder incompatible with Dolby Digital and with DTS Digital Surround.

Preference (System) setting procedure

Ex.: To select “16:9” for “TV SCREEN.”

1 Press SETUP.

Language selection menu appears on the TV screen. 

2 Press Cursor ► (or ◀) to select (highlight) the system setting menu.

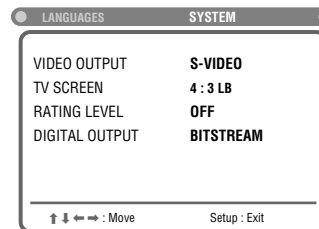

3 Press Cursor ▼ (or ▲) to select (highlight) one of the system setting items listed on the menu.

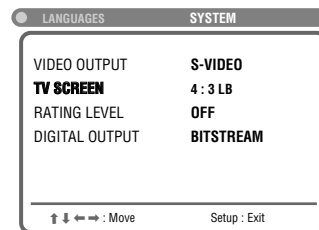

4 Press ENTER.

Pop-up window appears (where the selectable settings are listed). 

✓ indicates the current setting.

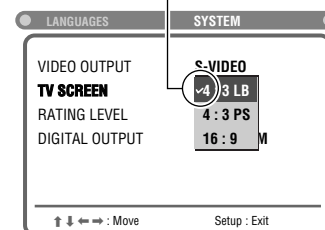

5 Press Cursor ▼ (or ▲) to select (highlight) the proper setting, then press ENTER.

The setting is stored (and the pop-up window goes off). 

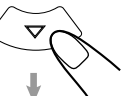
To cancel the setting you have just made, press RETURN without pressing ENTER. (Pop-up menu also goes off.) 

6 Repeat steps 4 and 5 to select the other system setting items listed.

To erase the Setup menu, press SETUP. 

Setting the Parental Lock

Using this function, you can restrict playback of DVD containing violent scenes and those not suitable for your family members.

Nobody can play such a disc unless this function is canceled. (“PARENTAL LEVEL” appears on the display if you try to play back such a disc.)

- This setting takes effect only for the DVDs containing the rating level information—Level 1 (most restrictive) to Level 8 (least restrictive).

1 Press SETUP.

Language selection menu appears on the TV screen.



2 Press Cursor ► (or ◀) to select (highlight) the system setting menu.

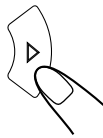

LANGUAGES	SYSTEM
VIDEO OUTPUT	S-VIDEO
TV SCREEN	4 : 3 LB
RATING LEVEL	OFF
DIGITAL OUTPUT	BITSTREAM

3 Press Cursor ▼ (or ▲) to select (highlight) “RATING LEVEL.”

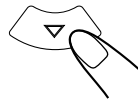

LANGUAGES	SYSTEM
VIDEO OUTPUT	S-VIDEO
TV SCREEN	4 : 3 LB
RATING LEVEL	OFF
DIGITAL OUTPUT	BITSTREAM

4 Press ENTER.

“RATING LEVEL” now changes “ENTER PASSWORD” on the menu.



LANGUAGES	SYSTEM
VIDEO OUTPUT	S-VIDEO
TV SCREEN	4 : 3 LB
ENTER PASSWORD	◆◆◆◆
DIGITAL OUTPUT	BITSTREAM

5 Press the number buttons to enter the password (4 digits).

- When shipped from the factory, password is “7890.”
- If you enter a wrong password, repeat from step 4 again.

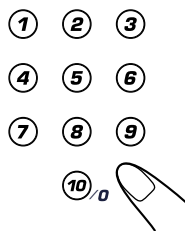

LANGUAGES	SYSTEM
VIDEO OUTPUT	S-VIDEO
TV SCREEN	4 : 3 LB
ENTER PASSWORD	◆◆◆◆
DIGITAL OUTPUT	BITSTREAM

➔

LANGUAGES	SYSTEM
VIDEO OUTPUT	S-VIDEO
TV SCREEN	4 : 3 LB
RATING LEVEL	OFF
DIGITAL OUTPUT	1
	2
	3
	4
	5

6 Press Cursor ▼ (or ▲) to select (highlight) the level you want, then press ENTER.

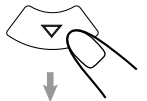

To erase the Setup menu, press SETUP.

To cancel Parental Lock, follow the procedure above but select “OFF” in step 6.

■ To change the password

1 Repeat steps 1 to 5 of “Setting the Parental Level” procedure.

2 Press Cursor ▼ (or ▲) to select (highlight) “NEW PASSWORD,” then ENTER.

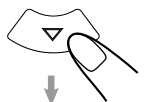

LANGUAGES	SYSTEM
VIDEO OUTPUT	S-VIDEO
TV SCREEN	4 : 3 LB
RATING LEVEL	4
DIGITAL OUTPUT	BITSTREAM

➔

LANGUAGES	SYSTEM
VIDEO OUTPUT	S-VIDEO
TV SCREEN	4 : 3 LB
NEW PASSWORD	◆◆◆◆
DIGITAL OUTPUT	BITSTREAM

- “NEW PASSWORD” is the last item listed on the pop-up window. If it is not shown, pressing Cursor ▼ repeatedly will show it in the pop-up window.

3 Press the number buttons to enter a new password (4 digits), then ENTER.

Your new password is now stored.



To erase the Setup menu, press SETUP.

■ To reset the password

You can reset the password to the initial setting “7890.” REMEMBER all the other preset settings such as the clock, preset stations, timer settings, DVD setup menu settings are also reset to the factory settings.

While the unit is turned off (on standby), press and hold TAPE B until the DVD VIDEO lamp on the unit flashes once.

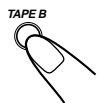

Playing Back Tapes

Playing Back a Tape

You can play back only type I tape.

1 Press EJECT (▲) for the deck you want to use.

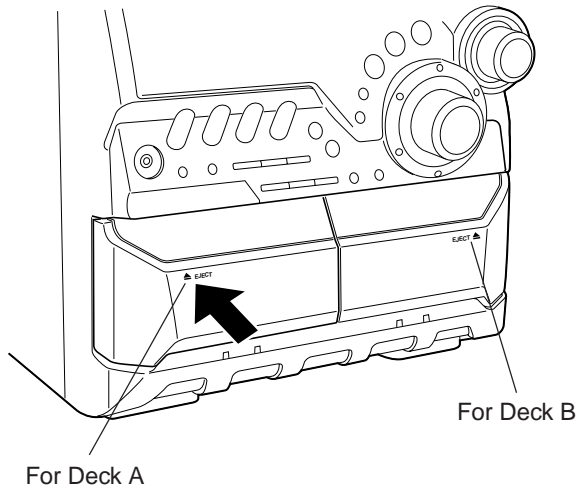

2 Put a cassette in with the exposed part of the tape down.

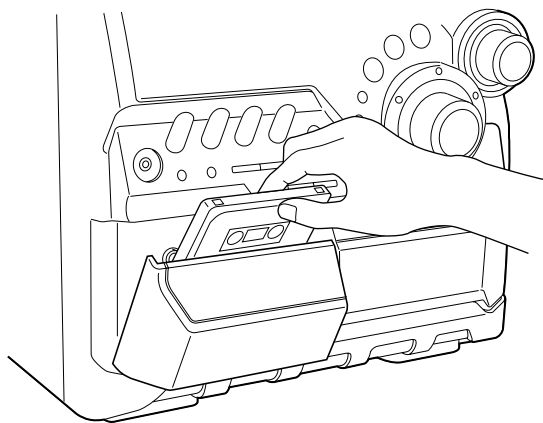

3 Close the cassette holder gently.

If you put cassettes in both decks A and B, the last deck which you have put a cassette into is selected.

To operate the other deck, press TAPE A or TAPE B (or TAPE A/B on the remote control).

4 Press TAPE ◀▶.

The tape play starts and the tape direction indicator (◀ or ▶) starts flashing slowly to indicate the tape running direction.

• Each time you press the button, the tape direction changes.

- ▶: plays the front side.
- ◀: plays the reverse side.

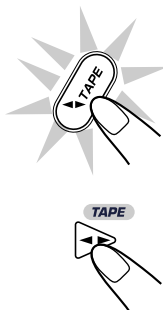

When the tape plays to the end, the deck automatically stops if the Reverse Mode is canceled. (See “To play both sides repeatedly — Reverse Mode.”)

To stop during play, press ■.

To operate the other deck, press TAPE A or TAPE B (or TAPE A/B on the remote control), then TAPE ◀▶.

To fast wind to the left or to the right, press ◀◀ or ▶▶. The tape direction indicator (◀ or ▶) starts flashing quickly on the display.

To remove the cassette, press ▲ EJECT for deck A or EJECT ▲ for deck B.

To play both sides repeatedly — Reverse Mode

Reverse Mode works for both decks at the same time. When it is in use, the tape automatically reverses at the end of a side and the unit starts playing the other side of the tape, and repeats the same process.

To use Reverse Mode, press REVERSE MODE so that the Reverse Mode indicator on the display lights up as — (↔)

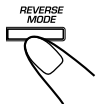

To cancel Reverse Mode, press the button again so that the Reverse Mode indicator on the display lights up as — →

notes When Reverse Mode is on with cassettes in both decks A and B

After the reverse side (◀) of the tape finishes playing, the tape in the other deck starts playing.



The use of the C-120 or thinner tape is not recommended, since characteristic deterioration may occur and this tape easily jams in the pinch-rollers and the capstans.

IMPORTANT:

- It should be noted that it may be unlawful to re-record pre-recorded tapes, records, or discs without the consent of the owner of copyright in the sound or video recording, broadcast or cable programme and in any literary, dramatic, musical, or artistic embodied therein.
- The recording level is automatically set correctly, so it is not affected by the VOLUME control, the SOUND MODE control, and the SUBWOOFER LEVEL control. Thus, during recording you can adjust the sound you are actually listening to without affecting the recording level.
- If recordings you have made have excessive noise or static, the unit may be too close to a TV. Place the unit away from the TV.
- You can use type I tape for recording.

To protect your recording

Cassettes have two small tabs on the back to protect unexpected erasure or re-recording.

To protect your recording, remove these tabs.

To re-record on a protected tape, cover the holes with adhesive tape.

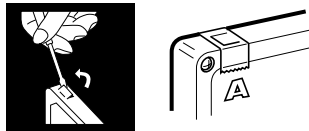

To keep the best recording and playback sound quality

If the heads, capstans, and pinch rollers of the cassette decks become dirty, the following will occur:

- Impaired sound quality
- Discontinuous sound
- Fading
- Incomplete erasure
- Difficulty in recording

To clean the heads, capstans, and pinch rollers

Use a cotton swab moistened with alcohol.

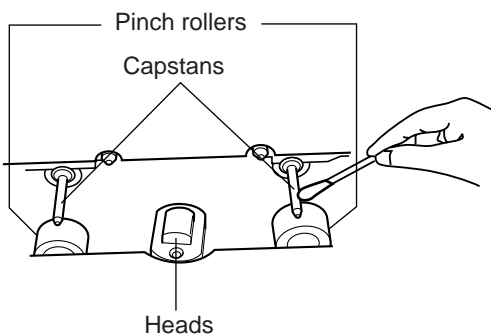

To demagnetize the heads

Turn off the unit, and use a head demagnetizer (available at electronics and audio shops).

Recording a Tape on Deck B

On the unit ONLY:

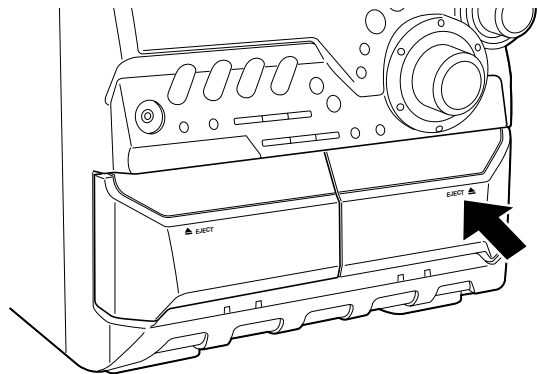

1 Press EJECT  for the deck B.



2 Put a recordable cassette in with the exposed part of the tape down.

3 Close the cassette holder gently.

4 Check the tape direction of deck B.

- If the tape direction is not correct, press TAPE   twice then  to change the tape direction.

5 Start playing the source — FM, AM, DVD player or auxiliary equipment connected to AUX IN jacks.

- When you want to use the dubbing method, see “Dubbing Tapes” on page 33.
- When the source is a disc, you can also use CD Synchronized Recording (see “CD Synchronized Recording” on page 33.)

6 Press REC START/STOP.

The REC (recording) indicator lights up on the display and recording starts.





To stop during recording, press REC START/STOP again or .

To remove the cassette, press EJECT  for deck B.

To record on both sides — Reverse Mode

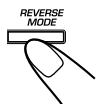
Press REVERSE MODE so that the Reverse Mode indicator lights up as .



- When using the Reverse Mode for recording, start recording in the forward direction () first. Otherwise, recording will stop when recording is done only on one side (reverse) of the tape.

To cancel Reverse Mode, press the button again so that the Reverse Mode indicator lights up as .

Dubbing Tapes

When dubbing on tapes, it is recommended to dub on the tapes of the same length and of the same quality as used for source tapes.

On the unit ONLY:

1 Press TAPE ◀▶, then ■.

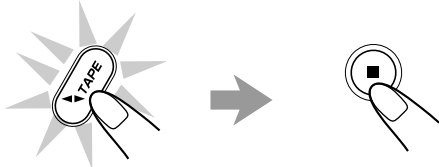

2 Put the source cassette in deck A, and a recordable cassette into deck B.

3 Press DUBBING.

Dubbing starts.
“DUBBING” appears, and the REC (recording) indicator lights up on the display.

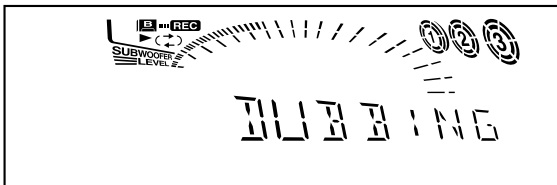

To stop during dubbing, press ■.

To remove the cassette, press ▲ EJECT for deck A and EJECT ▲ for deck B.

To record on both sides — Reverse Mode

Press REVERSE MODE so that the Reverse Mode indicator lights up as — (↔)



To cancel Reverse Mode, press the button again so that the Reverse Mode indicator lights up as — → ←

CD Synchronized Recording

You can easily record a disc onto a tape.

- You can also record the tracks in order you have made the program.

On the unit ONLY:

1 Put a recordable cassette into deck B.

2 Place a disc correctly on the circle of the disc tray, with its label side up.

3 Press one of the disc number buttons (DVD1, DVD2 or DVD3) to select the disc, then ■.

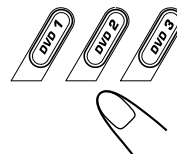

4 Press CD REC START.

“CD REC” appears, and the REC (recording) indicator lights up on the display.

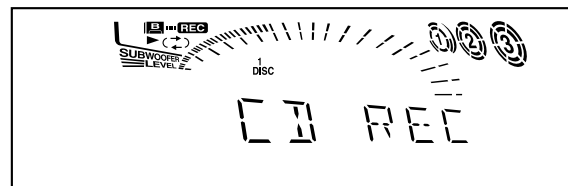
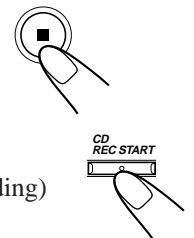

Deck B starts recording and the DVD player starts playing.

When the recording is done, the DVD player and deck B stop.

To stop during CD Synchronized Recording, press ■.

To remove the cassette, press EJECT ▲ for deck B.

To record on both sides — Reverse Mode

Press REVERSE MODE so that the Reverse Mode indicator lights up as — (↔)

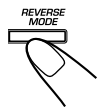

- When using the Reverse Mode for CD Synchronized Recording, start recording in the forward direction (▶) first. When the tape reaches its end while recording a song in the forward direction (▶), the last song will be recorded again at the beginning of the reverse side (◀).

To cancel Reverse Mode, press the button again so that the Reverse Mode indicator lights up as — → ←



You cannot start CD Synchronized Recording from the reverse direction (◀)

Even you try to start recording from the reverse direction (◀), the unit automatically changes the direction and start recording from forward direction (▶).

Using the Timers

There are three timers available — Daily Timer, Recording Timer, and Sleep Timer.

Before using the timers, you need to set the clock built in the unit. (See “Setting the Clock” on page 10.)

Using Daily Timer

With Daily Timer, you can wake to your favorite music or radio program. You can set the timer whether the unit is on or off.

How Daily Timer actually works

The unit automatically turns on, set the volume level to the preset level gradually, and starts playing the specified source when the on-time comes (the ☺ indicator flashes while the timer is operating). Then, when the off-time comes, the unit automatically turns off (stands by).

Daily Timer works every day until you cancel it.

- There is a time limit in doing the following steps. If the setting is canceled before you finish, start from step 1 again.
- If you have made a mistake while setting timer, press CANCEL/DEMO. (However, this does not always work. If CANCEL/DEMO does not work, press CLOCK/TIMER repeatedly and start from step 1 again.)

Before you start...

- *When using a disc as the source to play —*
 - Make sure there is a disc on the currently selected disc number tray.
- *When using a tape as the source to play —*
 - Make sure that a tape is in the deck whose deck indicator (A or B) is lit on the display.
- *When using the external component as the source to play —*
 - Set the timer equipped with the external component at the same time.

On the unit ONLY:

1 Press CLOCK/TIMER repeatedly until “DAILY” appears on the display.

The ☺ indicator lights up and the DAILY (daily timer) indicator also starts flashing on the display.

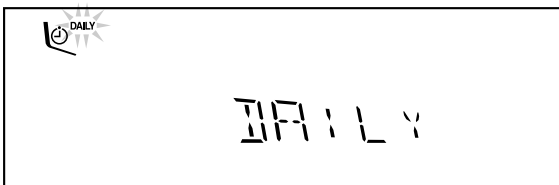

- Each time you press the button, the timer setting modes change as follows:

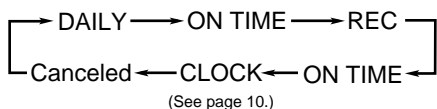

2 Press CLOCK/TIMER again.

“ON TIME” appears for 2 seconds, then the unit enters on-time setting mode.



3 Set the on-time you want the unit to turn on.

- 1) Press ◀◀ or ▶▶ to set the hour, then press SET.
 - 2) Press ◀◀ or ▶▶ to set the minute, then press SET.
- “OFF TIME” appears for 2 seconds, then the unit enters off-time setting mode.

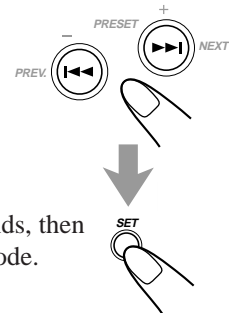

4 Set the off-time you want the unit to turn off (on standby).

- 1) Press ◀◀ or ▶▶ to set the hour, then press SET.
 - 2) Press ◀◀ or ▶▶ to set the minute, then press SET.
- The unit enters source selecting mode.

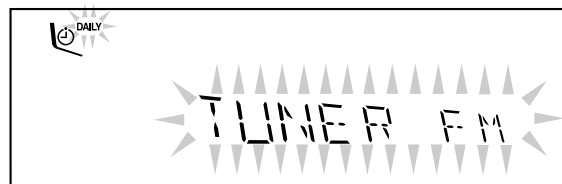
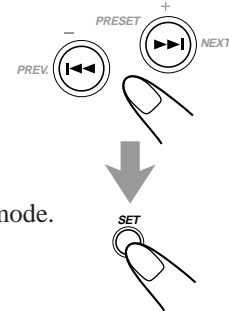

5 Press ◀◀ or ▶▶ to select the source to play, then press SET.

- Each time you press ◀◀ or ▶▶, the source changes as follows:

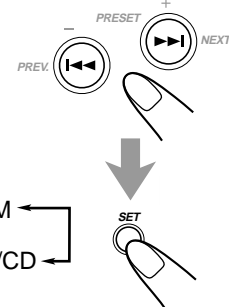

TUNER FM: tunes into a specified preset FM station. → go to step 6.

TUNER AM: tunes into a specified preset AM station. → go to step 6.

DVD/CD: plays a disc. → go to step 7.

TAPE: plays a tape in deck A or B. → go to step 7.

AUX: plays an external source. → go to step 7.

6 When you have selected “TUNER FM” or “TUNER AM” in step 5, select a preset station number.

Press ◀◀ or ▶▶ to select the preset station number, then press SET.
The unit enters volume setting mode.

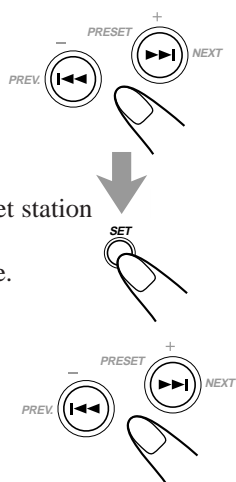

7 Press ◀◀ or ▶▶ to set the volume level.

- You can select the volume level from VOL MIN, VOL 1 — VOL 30, and VOL MAX.

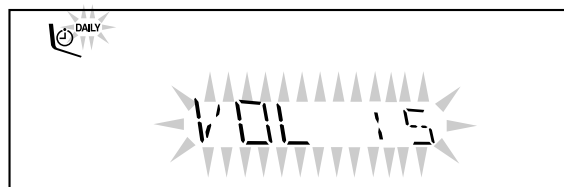

8 Press SET to complete the Daily Timer setting.

The DAILY (daily timer) indicator stops flashing and remains lit. The settings you have done are shown on the display in sequence for your confirmation.

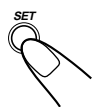

9 Press ⏻/STANDBY/ON to turn off the unit (on standby) if you have set the Daily Timer with the unit turned on.

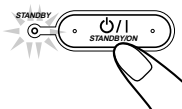

If the unit is turned on when the timer-on time comes Daily Timer does not work.

To turn on or off Daily Timer after its setting is done

1 Press CLOCK/TIMER repeatedly until “DAILY” appears on the display.



2 To turn off the Daily Timer, press CANCEL/DEMO.

The DAILY (daily timer) indicator goes off from the display (“OFF” appears for a while). The Daily Timer is canceled, but the setting for the Daily Timer remains in memory.



To turn on the Daily Timer, press SET.

The DAILY (daily timer) indicator lights up on the display. The settings you have done are shown on the display in sequence for your confirmation.

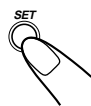

Using Recording Timer

With Recording Timer, you can make a tape of a radio broadcast automatically. You can set the timer whether the unit is on or off.

How Recording Timer actually works

The unit automatically turns on, tunes into the specified station, sets the volume level to “VOL MIN,” and starts recording when the on-time comes (the ⏻ indicator flashes while the timer is operating). Then, when the off-time comes, the unit automatically turns off (stands by).

Recording Timer works only once, but the timer setting remains in memory until you change it.

- There is a time limit in doing the following steps. If the setting is canceled before you finish, start from step 1 again.
- If you have made a mistake while setting the timer, press CANCEL/DEMO. (However, this does not always work. If CANCEL/DEMO does not work, press CLOCK/TIMER repeatedly and start from step 2 again.)

On the unit ONLY:

1 Put a recordable cassette into deck B.

2 Press CLOCK/TIMER repeatedly until “REC” appears on the display.

The ⏻ indicator lights up and the REC (recording timer) indicator also starts flashing on the display.



- Each time you press the button, the timer setting modes change as follows:

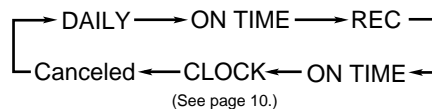



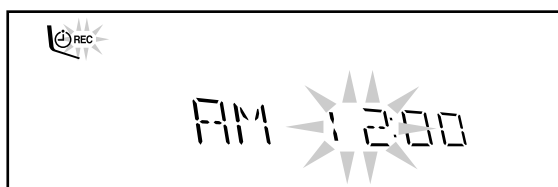

3 Press CLOCK/TIMER again.

“ON TIME” appears for 2 seconds, then the unit enters on-time setting mode.





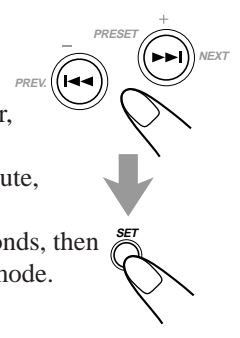

4 Set the on-time you want the unit to turn on.

- 1) Press  or  to set the hour, then press SET.
- 2) Press  or  to set the minute, then press SET.
"OFF TIME" appears for 2 seconds, then the unit enters off-time setting mode.





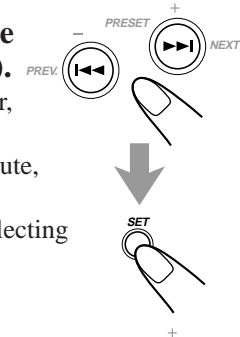

5 Set the off-time you want the unit to turn off (on standby).

- 1) Press  or  to set the hour, then press SET.
- 2) Press  or  to set the minute, then press SET.
The unit enters preset station selecting mode.



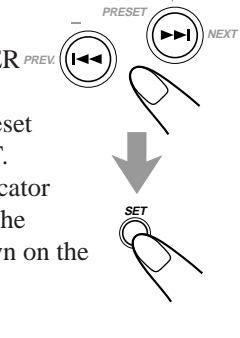

6 Select a preset station.

- 1) Press  or  to select the band ("TUNER FM" or "TUNER AM"), then press SET.
- 2) Press  or  to select a preset channel number, then press SET.
The REC (recording timer) indicator stops flashing and remains lit. The settings you have done are shown on the display in sequence for your confirmation.

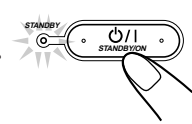

7 Press /STANDBY/ON to turn off the unit (on standby) if necessary.



If you want to listen to another source while recording Press REC START/STOP or  to stop recording. Without stopping it, you cannot change the source.

To turn on or off Recording Timer after its setting is done

1 Press **CLOCK/TIMER** repeatedly until "REC" appears on the display.



2 To turn off the Recording Timer, press **CANCEL/DEMO**.



The REC (recording timer) indicator goes off from the display ("OFF" appears for a while). The Recording Timer is canceled, but the setting for the Recording Timer remains in memory.

To turn on the Recording Timer, press **SET**. The REC (recording timer) indicator lights up on the display. The settings you have done are shown on the display in sequence for your confirmation.

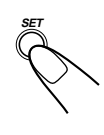

Using Sleep Timer

With Sleep Timer, you can fall asleep to music. You can set Sleep Timer when the unit is turned on.

How Sleep Timer actually works

The unit automatically turns off after the specified time length passes.

On the remote control ONLY:

1 Press SLEEP.

The time length until the shut-off time appears and the SLEEP indicator starts flashing on the display.



- Each time you press the button, the time length changes as follows:

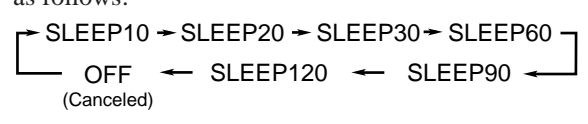

2 Wait for about 5 seconds after specifying the time length.

The SLEEP indicator stops flashing and remains lit.

To check the remaining time until the shut-off time, press SLEEP once so that the remaining time until the shut-off time appears for about 5 seconds.

To change the shut-off time, press SLEEP repeatedly until the desired time length appears on the display.

To cancel the setting, press SLEEP repeatedly until "OFF" appears on the display so that the SLEEP indicator goes off from the display.

- Sleep Timer is also canceled when you turn off the unit.

Timer Priority

Since each timer can be set separately, you may wonder what happens if the setting for these timers overlaps. Here are examples.

- If Recording Timer and Daily Timer has the same timer on-time, Recording Timer has priority over Daily Timer.
- If Sleep Timer overlaps with another timer (either Daily Timer or Recording Timer), a timer with the earlier shut-off time has priority.

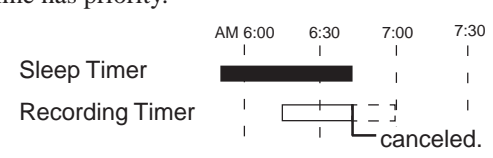

When using the Recording Timer and Sleep Timer at the same time, pay special attention to the shut-off time.

Maintenance

To get the best performance of the unit, keep your discs, tapes, and mechanism clean.

Handling discs



- Remove the disc from its case by holding it at the edge while pressing the center hole lightly.
- Do not touch the shiny surface of the disc, or bend the disc.
- Put the disc back in its case after use to prevent warping.

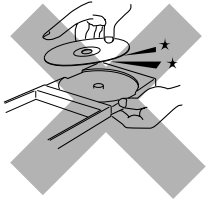

- Be careful not to scratch the surface of the disc when placing it back in its case.
- Avoid exposure to direct sunlight, temperature extremes, and moisture.



To clean the disc

Wipe the disc with a soft cloth in a straight line from center to edge.

Handling cassette tapes

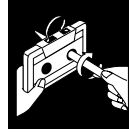

- If the tape is loose in its cassette, take up the slack by inserting a pencil in one of the reels and rotating.
- If the tape is loose, it may get stretched, cut, or caught in the cassette.

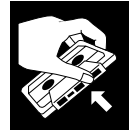

- Be careful not to touch the tape surface.



- Avoid the following places to store the tape:
 - In dusty places
 - In direct sunlight or heat
 - In moist areas
 - Near a magnet



DO NOT use any solvent — such as conventional record cleaner, spray, thinner, or benzene — to clean the disc.

Troubleshooting

If you are having a problem with your unit, check this list for a possible solution before calling for service.

If you cannot solve the problem from the hints given here, or the unit has been physically damaged, call a qualified person, such as your dealer, for service.

	Symptom	Cause	Action
FM/AM	Hard to listen to broadcasts because of noise.	<ul style="list-style-type: none"> • Antennas are disconnected. • The AM loop antenna is too close to the unit. • The FM antenna is not properly extended and positioned. 	<ul style="list-style-type: none"> • Reconnect the antennas correctly and securely. • Change the position and direction of the AM loop antenna. • Extend the FM antenna at the best position.
	No sound is heard.	Connections are incorrect or loose.	Check all connections and make corrections. (See pages 6 to 9.)
DISC GENERAL	The disc sound is discontinuous.	The disc is scratched or dirty.	Clean or replace the disc. (See page 37.)
	The carousel does not open or close.	<ul style="list-style-type: none"> • The AC power cord is not plugged in. • The carousel is locked. 	<ul style="list-style-type: none"> • Plug the AC power cord. • Unlock the carousel. (See page 16.)
	The disc does not play.	The disc is placed upside down.	Place the disc with the label side up.
	No picture appears on the screen.	<ul style="list-style-type: none"> • The video cord is not connected correctly. • An incorrect input has been selected on the TV or monitor. 	<ul style="list-style-type: none"> • Connect the video cord correctly. • Select the correct input on the TV or monitor.
DVD	The left and right edges of the wide picture (16:9) are missing.	“4:3 PS” is selected when viewing on a conventional TV (aspect ratio 4:3).	Select “4:3 LB.” (See page 29.)
	No subtitle appears on the display though you have selected the initial subtitle language.	_____	Some DVDs are programed to always display no subtitle initially. If this happens, press SUBTITLE on the remote control after starting play.
	Audio language is different from the one you have selected as the initial audio language.	_____	Some DVDs are programed to always use the original language initially. If this happens, press AUDIO on the remote control after starting play.
	No sound is heard.	You are playing a disc with DTS Digital Surround.	This unit cannot output DTS sound without connecting a decoder compatible with DTS Digital Surround.
	Unable to operate the DVD player as you intend to do.	The built-in microprocessor may malfunction due to external electrical interference.	Press and hold DUBBING until “INITIAL” appears on the display (so that you can operate the DVD player normally).
TAPE	The cassette holders cannot be opened.	Power supply from the AC power cord has been cut off while the tape was running.	Turn on the unit.
	Impossible to record.	Small tabs on the back of the cassette are removed.	Cover the holes with adhesive tape.
GENERAL	Display demonstration starts automatically during play.	Display demonstration has not been canceled yet.	Press CANCEL/DEMO on the unit. (See page 9.)
	Operations are disabled.	The built-in microprocessor may malfunction due to external electrical interference.	Unplug the AC power cord and then plug it back in.
	Unable to operate the unit from the remote control.	<ul style="list-style-type: none"> • The path between the remote control and the remote sensor on the unit is blocked. • The batteries are exhausted. 	<ul style="list-style-type: none"> • Remove the obstruction. • Replace the batteries.

Glossary

Dolby Digital

This is a digital audio compression format that was developed by Dolby Laboratories. Dolby Digital encoding method (so-called discrete 5.1 channel digital audio format) records and compresses the left front channel, right front channel, center channel, left rear channel, right rear channel, and LFE channel (total 6 channels, but LFE channel is counted as 0.1 channel, therefore called 5.1 channels) signals digitally. Each channel is completely independent from other channel signals to avoid interference, therefore, you can obtain much better sound quality with stereo and surround effects.

To reproduce these original surround signals, you need to connect an amplifier or a decoder compatible with Dolby Digital.

DTS Digital Surround

Another discrete 5.1 channel digital audio format, available on CD, LD, and DVD software, developed by Digital Theater Systems, Inc.

Compared to Dolby Digital, audio compression rate is relatively low. This fact allows DTS Digital Surround format to add breadth and depth to the reproduced sounds. As a result, DTS Digital Surround features natural, solid and clear sound.

To reproduce these surround signals, you need to connect an amplifier or a decoder compatible with DTS Digital Surround.

Linear PCM

This is a digital recording format that is used for audio CDs.

Playback Control (PBC)

When a VCD has the PBC (Playback Control) function, you can enjoy menu-driven operations and high-resolution still pictures.

Sampling Frequency, Quantization Bits

When analog signals are converted into digital signals, they are divided into many points and digitized. This dividing method is called "sampling." The sampling frequency indicates how many points one second is divided into – for example, for CD sound, one second is divided into 44100 points since its sampling frequency is 44.1 kHz. On the other hand, the number of quantization bits indicates the volume size used to memorize each divided point.

The larger this number is, the clearer the sound can be reproduced.

Output signal through the DIGITAL OUT (OPTICAL) terminal varies according to the "DIGITAL OUT (OPTICAL)" setting. See "Setting the DVD Preference (System)" on page 29.

Playback Disc	DIGITAL OUT	BITSTREAM	LPCM
	Output Signals		
DVD	48 kHz, Linear PCM	48 kHz, Linear PCM	48 kHz, Linear PCM
	96 kHz, Linear PCM	48 kHz, Linear PCM	48 kHz, Linear PCM
	128 kHz, Linear PCM	48 kHz, Linear PCM	48 kHz, Linear PCM
	Dolby Digital	Dolby Digital bitstream	Down mixed (2 channels)
	DTS Digital Surround	DTS bitstream	None
Video CD, Audio CD	44.1 kHz, 16 bit Linear PCM	44.1 kHz, 16 bit Linear PCM	44.1 kHz, 16 bit Linear PCM
Audio DTS CD	DTS Digital Surround	DTS bitstream	None

Amplifier section — CA-MXDVA5

Output Power

SUBWOOFERS: 80 W per channel, min. RMS, driven into 6 Ω at 63 Hz with no more than 10% total harmonic distortion.

MAIN SPEAKERS: 40 W per channel, min. RMS, driven into 4 Ω at 1 kHz with no more than 10% total harmonic distortion.

Audio input sensitivity/Impedance

(at 1 kHz, measured at MAIN SPEAKERS)

AUX IN: 400 mV/50 k Ω

Audio output level/Impedance

LINE OUT: 400 mV/4.7 k Ω

Digital output: DIGITAL OUT (OPTICAL)

Signal wave length: 660 nm

Output level: -21 dBm to -15 dBm

Speakers/Impedance:

Subwoofer: 6 Ω — 16 Ω

Main speaker: 4 Ω — 8 Ω

Tuner

FM tuning range: 87.50 MHz — 108.00 MHz

AM tuning range: 530 kHz — 1 710 kHz

DVD player

Disc Capacity: 3 discs

Frequency response DVD, fs=48 kHz : 16 Hz to 22 000 Hz

DVD, fs=96 kHz : 16 Hz to 44 000 Hz

VCD, CD: 16 Hz to 20 000 Hz

Dynamic range: 85 dB

Signal-to-noise ratio: 85 dB

Cassette deck

Frequency response

Normal (type I): 50 Hz — 14 000 Hz

Wow and flutter: 0.15% (WRMS)

General

Power requirement: AC 120 V \sim , 60 Hz

Power consumption: 180 W (at operation)

17 W (on standby)

Dimensions (approx.): 270 mm x 317 mm x 447 mm (W/H/D)

(10^{11/16} in. x 12^{1/2} in. x 17^{5/8} in.)

Mass (approx.): 9.9 kg (21.9 lbs)

Supplied accessories

See page 6.

Speaker section — SP-MXDVA5

Type: 3-way bass-reflex type

Twin Hyper Power-Drive Subwoofer

Speaker units: Subwoofer: 13.5 cm (5^{3/8} in.) cone x1

Main Woofer: 13.5 cm (5^{3/8} in.) cone x1

Tweeter: 5 cm (2 in.) cone x1

Power handling capacity: Subwoofer: 80 W

Main speaker: 40 W

Impedance: Subwoofer: 6 Ω

Main speaker: 4 Ω

Frequency range: Subwoofer: 26 Hz — 92 Hz

Main speaker: 92 Hz — 20 000 Hz

Sound pressure level: Subwoofer: 75 dB/W•m

Main speaker: 88 dB/W•m

Dimensions (approx.): 275 mm x 317 mm x 309 mm (W/H/D)

(10^{11/16} in. x 12^{1/2} in. x 12^{3/16} in.)

Mass (approx.): 5.0 kg (11.0 lbs) each

Authorized Service Centers

QUALITY **JVC**[®] SERVICE

HOW TO LOCATE YOUR JVC SERVICE CENTER

TOLL FREE: 1 (800) 537-5722

<http://www.jvc.com>

Dear Customer,

In order to receive the most satisfaction from your purchase, please read the instruction booklet before operating the unit. In the event that repairs are necessary, please call 1 (800)537-5722 for your nearest authorized servicer or visit our website at **www.JVC.com**

Remember to retain your Bill of Sale for Warranty Service.

Do not service the television yourself

Caution

To prevent electrical shock, do not open the cabinet. There are no user serviceable parts inside. Please refer to qualified service personnel for repairs.

Accessories

To purchase accessories for your JVC product, please call toll free:1 (800)882-2345 or on the web at **www.JVC.com**



LIMITED WARRANTY

AUDIO-1

JVC COMPANY OF AMERICA warrants this product and all parts thereof, except as set forth below ONLY TO THE ORIGINAL PURCHASER AT RETAIL to be FREE FROM DEFECTIVE MATERIALS AND WORKMANSHIP from the date of original retail purchase for the period as shown below. ("The Warranty Period")

PARTS	1 YR	LABOR	1 YR
-------	------	-------	------

THIS LIMITED WARRANTY IS VALID ONLY IN THE FIFTY (50) UNITED STATES, THE DISTRICT OF COLUMBIA AND IN COMMONWEALTH OF PUERTO RICO.

WHAT WE WILL DO:

If this product is found to be defective, JVC will repair or replace defective parts at no charge to the original owner. Such repair and replacement services shall be rendered by JVC during normal business hours at JVC authorized service centers. Parts used for replacement are warranted only for the remainder of the Warranty Period. All products and parts thereof may be brought to a JVC authorized service center on a carry-in basis except for Television sets having a screen size 25 inches and above which are covered on an in-home basis.

WHAT YOU MUST DO FOR WARRANTY SERVICE:

Return your product to a JVC authorized service center with a copy of your bill of sale. For your nearest JVC authorized service center, please call toll free: (800) 537-5722.

If service is not available locally, box the product carefully, preferably in the original carton, and ship, insured, with a copy of your bill of sale plus a letter of explanation of the problem to the nearest JVC Factory Service Center, the name and location of which will be given to you by the toll-free number.

If you have any questions concerning your JVC Product, please contact our Customer Relations Department.

WHAT IS NOT COVERED:

This limited warranty provided by JVC does not cover:

1. Products which have been subject to abuse, accident, alteration, modification, tampering, negligence, misuse, faulty installation, lack of reasonable care, or if repaired or serviced by anyone other than a service facility authorized by JVC to render such service, or if affixed to any attachment not provided with the products, or if the model number or serial number has been altered, tampered with, defaced or removed;
2. Initial installation and installation and removal for repair;
3. Operational adjustments covered in the Owner's Manual, normal maintenance, video and audio head cleaning;
4. Damage that occurs in shipment, due to act of God, and cosmetic damage;
5. Signal reception problems and failures due to line power surge;
6. Video Pick-up Tubes/CCD Image Sensor, Cartridge, Stylus (Needle) are covered for 90 days from the date of purchase;
7. Accessories
8. Batteries (except that Rechargeable Batteries are covered for 90 days from the date of purchase);

There are no express warranties except as listed above.

THE DURATION OF ANY IMPLIED WARRANTIES, INCLUDING THE IMPLIED WARRANTY OF MERCHANTABILITY, IS LIMITED TO THE DURATION OF THE EXPRESS WARRANTY HEREIN.

JVC SHALL NOT BE LIABLE FOR THE LOSS OF USE OF THE PRODUCT, INCONVENIENCE, LOSS OR ANY OTHER DAMAGES, WHETHER DIRECT, INCIDENTAL OR CONSEQUENTIAL (INCLUDING, WITHOUT LIMITATION, DAMAGE TO TAPES, RECORDS OR DISCS) RESULTING FROM THE USE OF THIS PRODUCT, OR ARISING OUT OF ANY BREACH OF THIS WARRANTY. ALL EXPRESS AND IMPLIED WARRANTIES, INCLUDING THE WARRANTIES OF MERCHANTABILITY AND FITNESS FOR PARTICULAR PURPOSE, ARE LIMITED TO THE WARRANTY PERIOD SET FORTH ABOVE.

Some states do not allow the exclusion of incidental or consequential damages or limitations on how long an implied warranty lasts, so these limitations or exclusions may not apply to you. This warranty gives you specific legal rights and you may also have other rights which vary from state to state.

JVC COMPANY OF AMERICA 1700 Valley Road
DIVISION OF JVC AMERICAS CORP. Wayne, NJ 07470

REFURBISHED PRODUCTS CARRY A SEPARATE WARRANTY, THIS WARRANTY DOES NOT APPLY. FOR DETAILS OF REFURBISHED PRODUCT WARRANTY, PLEASE REFER TO THE REFURBISHED PRODUCT WARRANTY INFORMATION PACKAGED WITH EACH REFURBISHED PRODUCT.

For customer use:

Enter below the Model No. which is located either on the rear, bottom or side of the cabinet. Retain this information for future reference.

Model No. : MX-DVA5

Serial No. :

Purchase date :

Name of dealer :

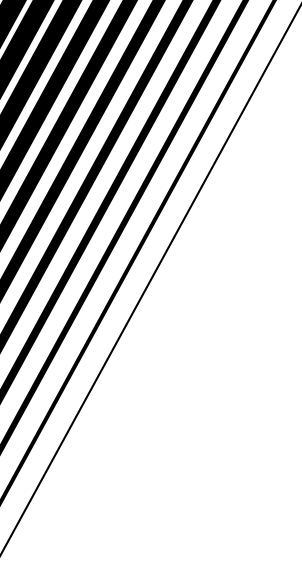

JVC
VICTOR COMPANY OF JAPAN, LIMITED